

QUILL TYP 20

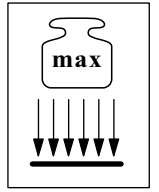

20

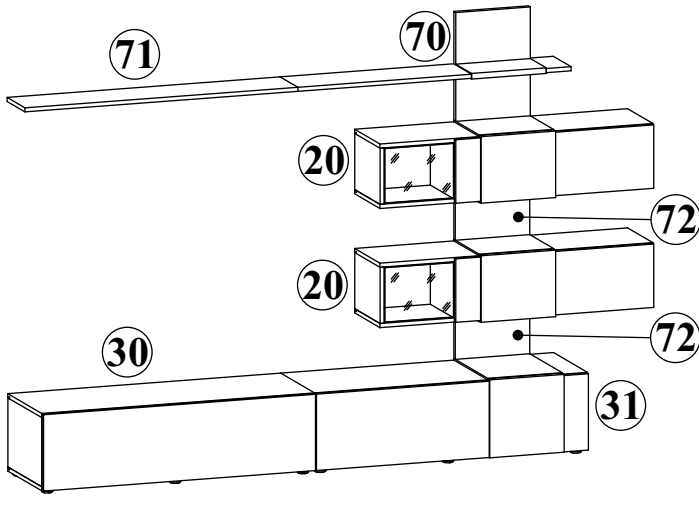

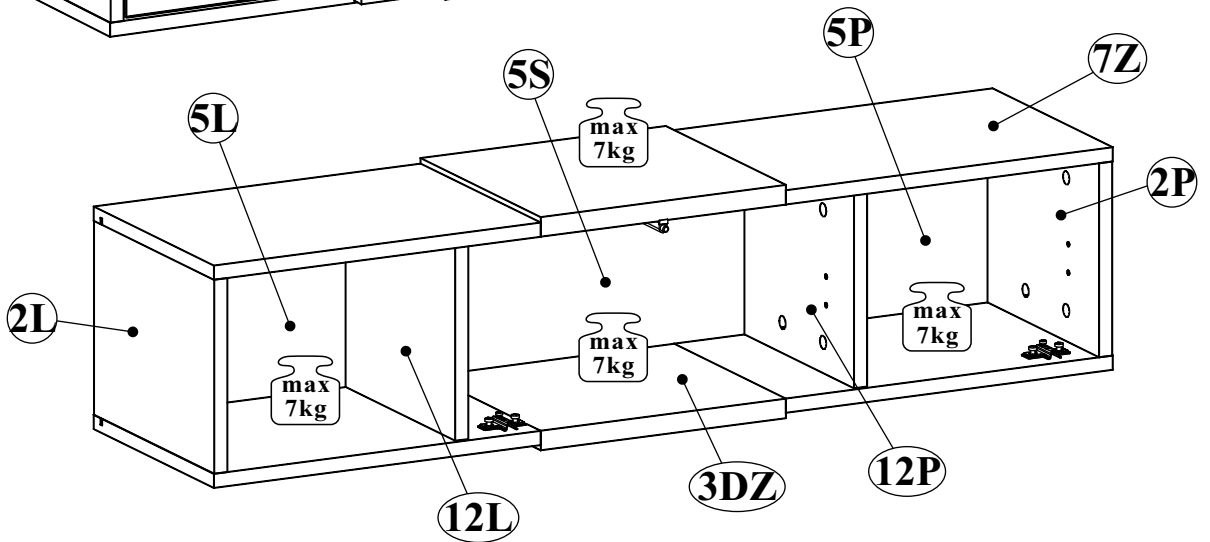
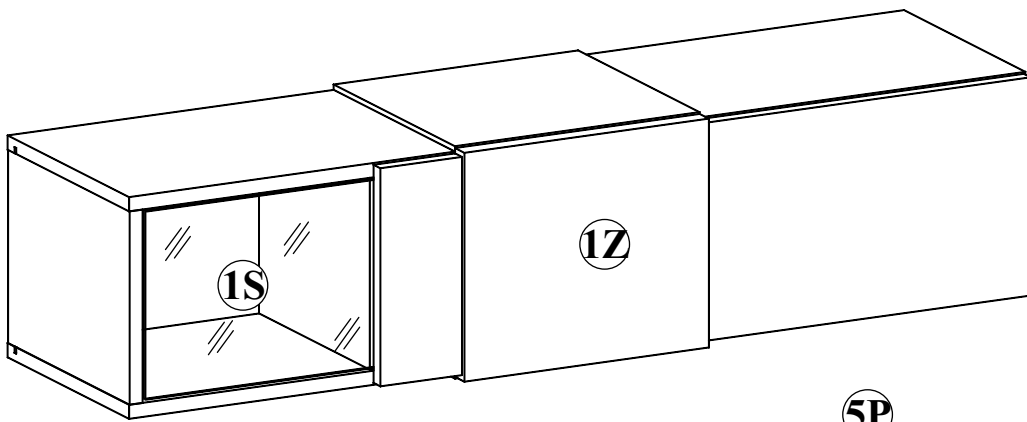

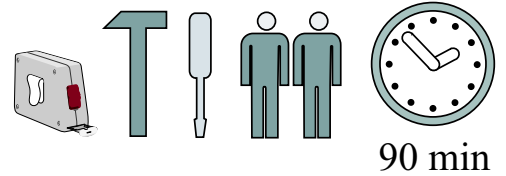





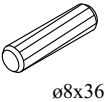
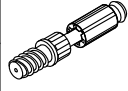

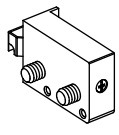
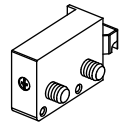
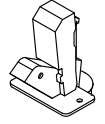
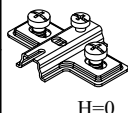
NO	Dim.		Col.-No	Qty
1Z	246	798	16	1
1S	315	212	4	1
2L	218	284	16	1
2P	218	284	16	1
12L	218	259	16	1
12P	218	259	16	1
3DZ	1100	284	16	1
5L	230	295	3	1
5S	230	488	3	1
5P	230	295	3	1
7Z	1100	284	16	1

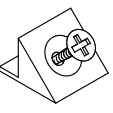
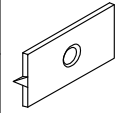

90 min

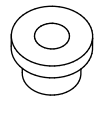
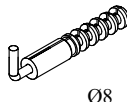
QUILL TYP 20

A1 x16  ø8x36	B4 x16 	B5 x16  Ø15x12	G5 x16 	ZXL x2 	ZXP x2 
E10 x2 	E11 x2  H=0	D10 X10  USØ3,5x13	G21 x2 	D7 x6  USØ3x16	OD2 x1 
S1 x10 	G16 x4 	UP13 x7  UPØ3x16	P2 x3 	KR2 x4  ø8	G2 x1 

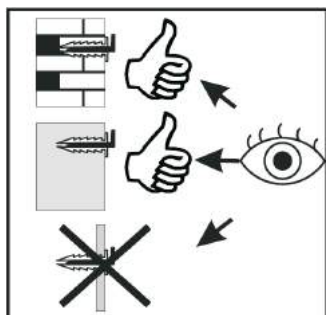
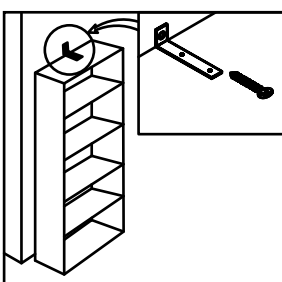
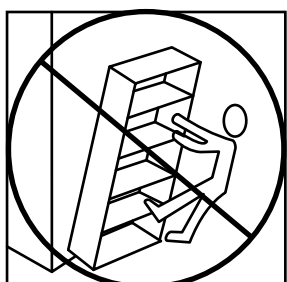
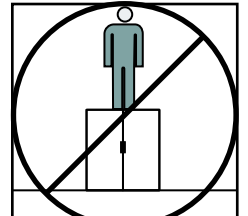
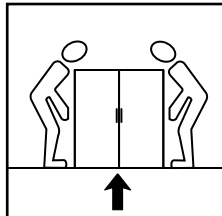
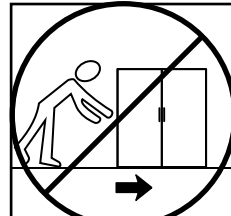
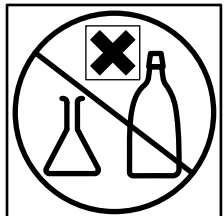
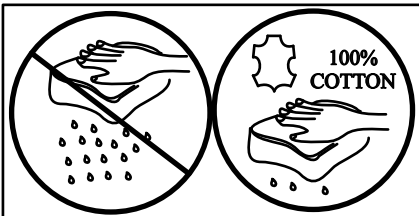
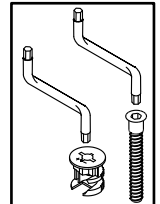
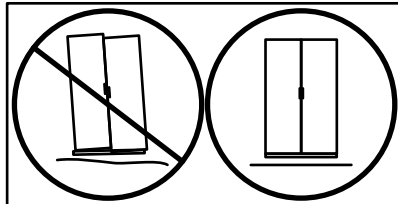
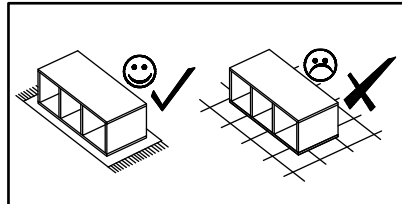
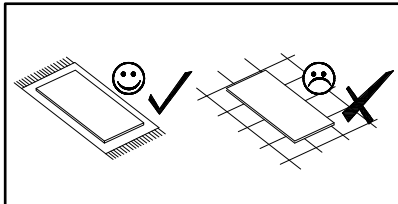
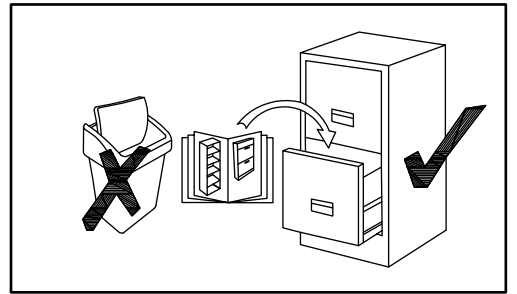
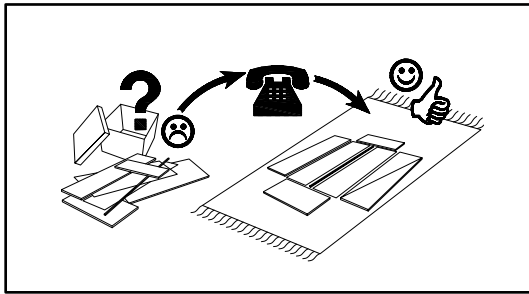
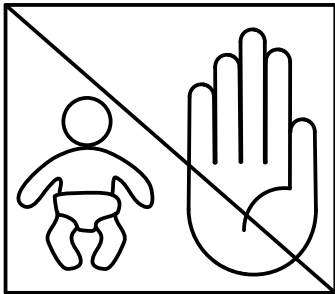
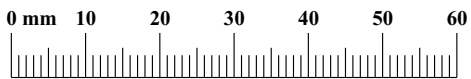

QUILL TYP 20

1

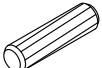
A1	
x16	ø8x36

B5	
x16	Ø15x12

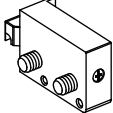
ZXL	
x2	

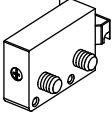
ZXP	
x2	

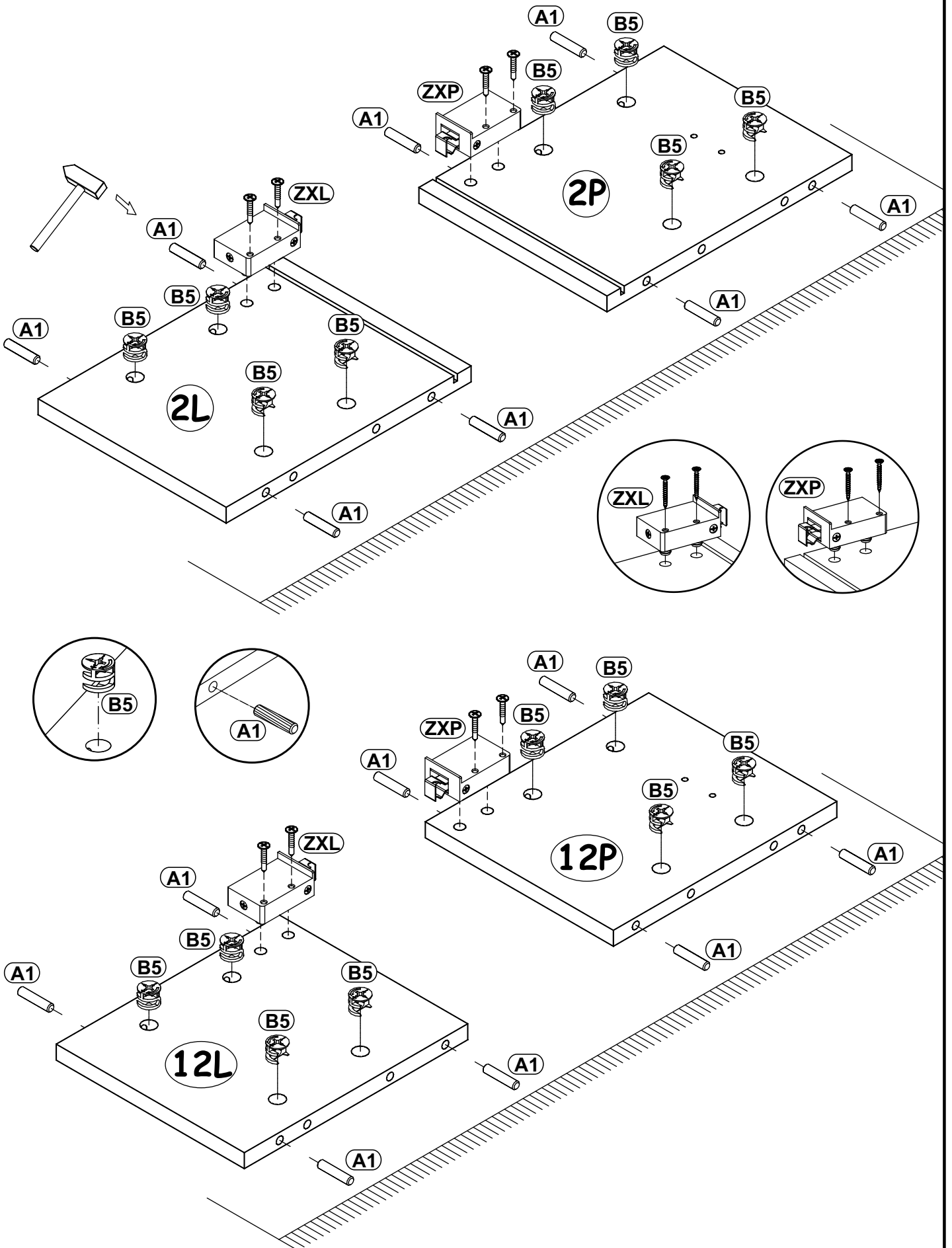

QUILL TYP 20

2

OD2		D10		B4	
x1		x2	USØ3,5x13	x8	

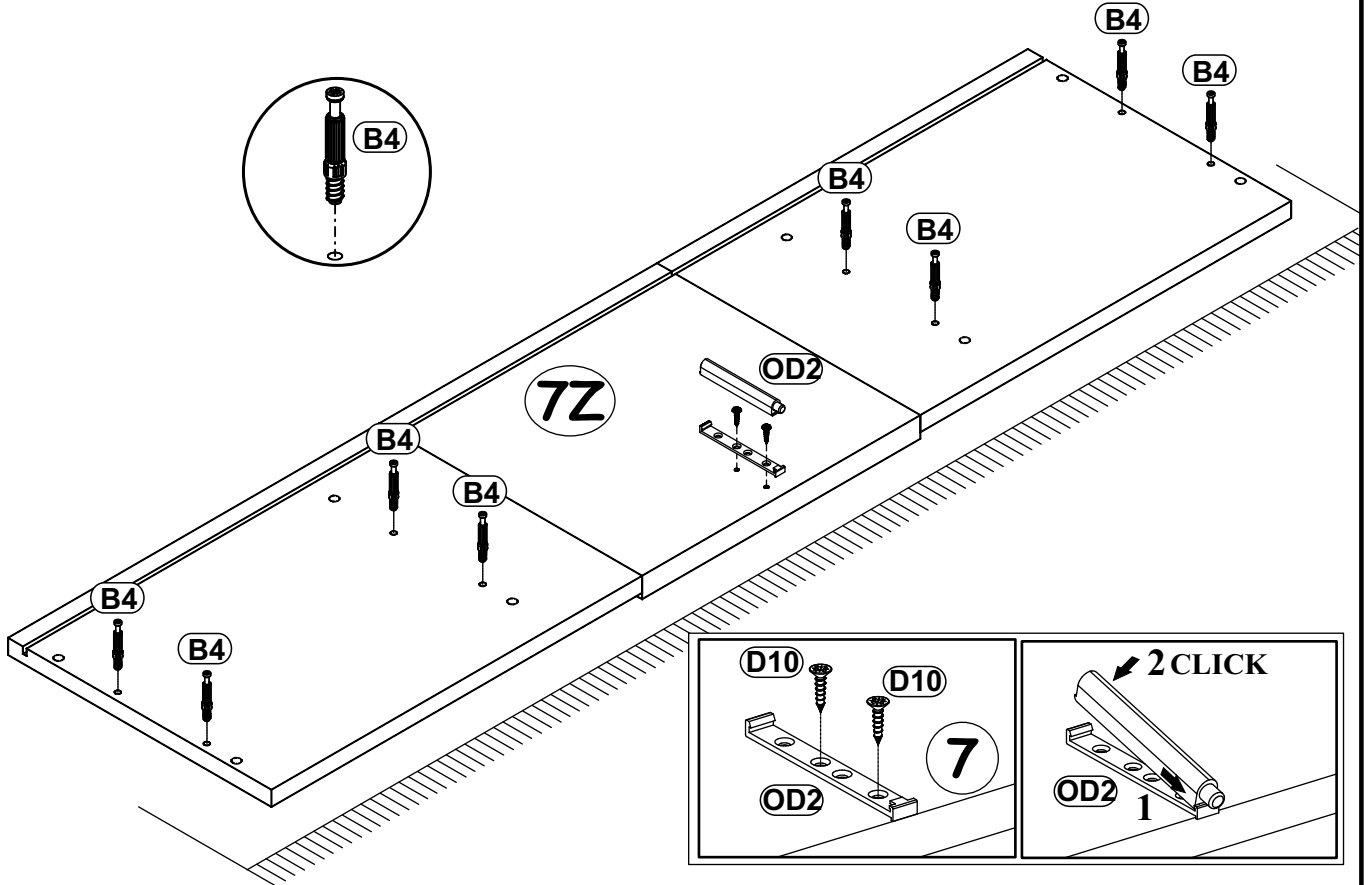

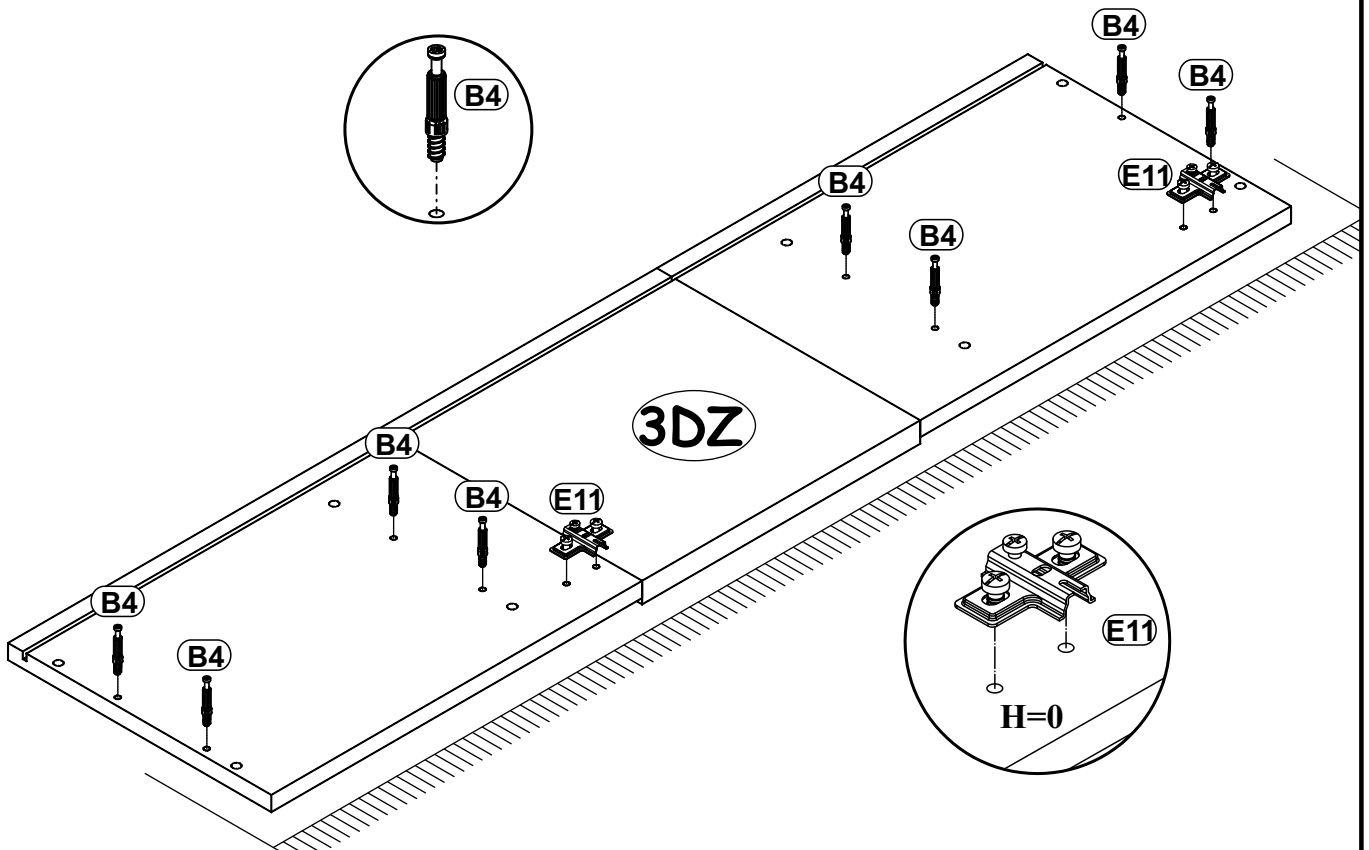

3

B4		E11	
x8		x2	H=0

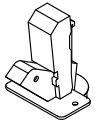
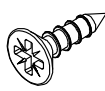

QUILL TYP 20

4

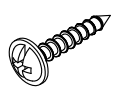
E10		D10		P2		UP13	
x2		x4	USØ3,5x13	x3		x3	UPØ3x16

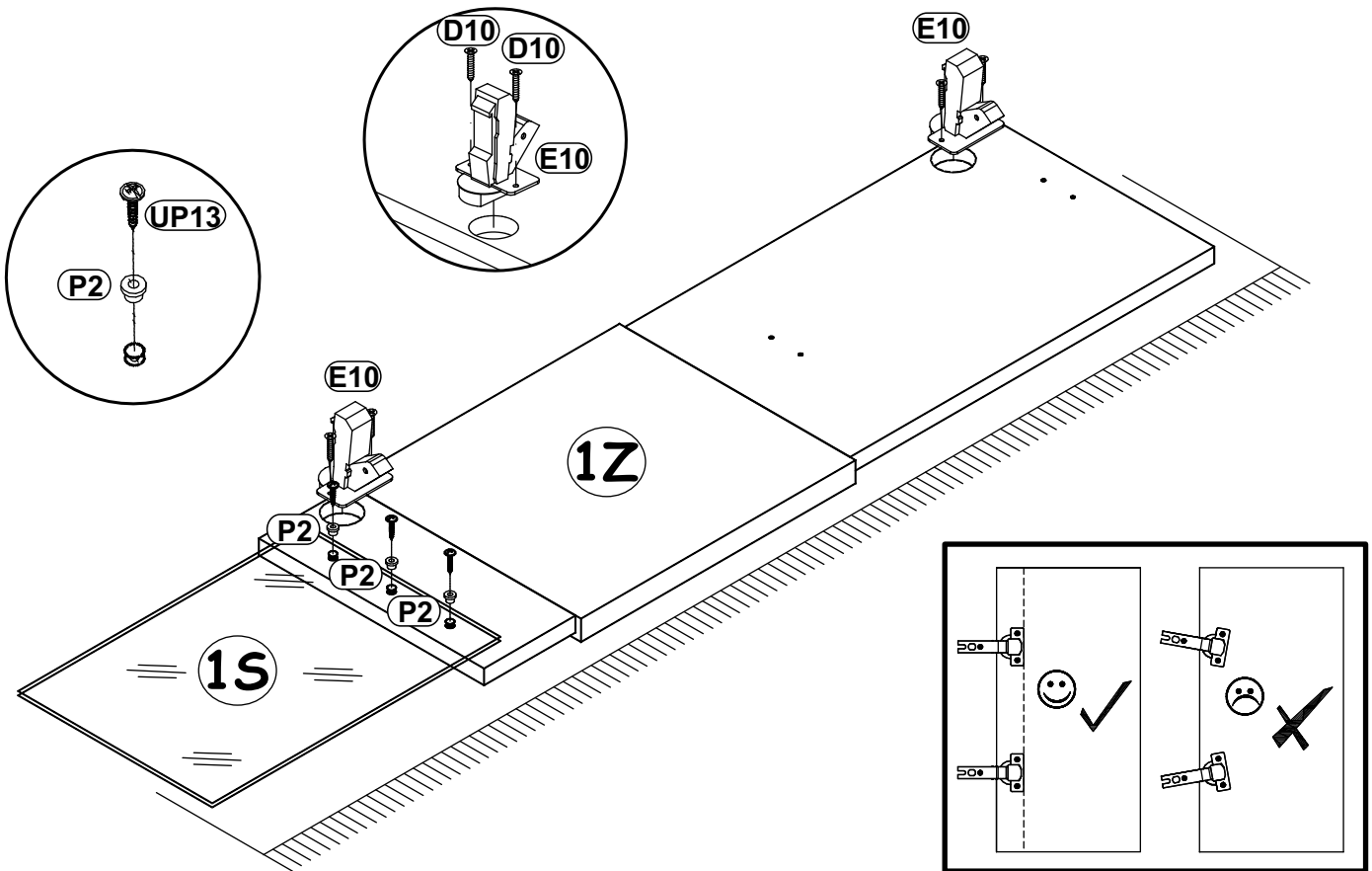

5

G5	
x8	

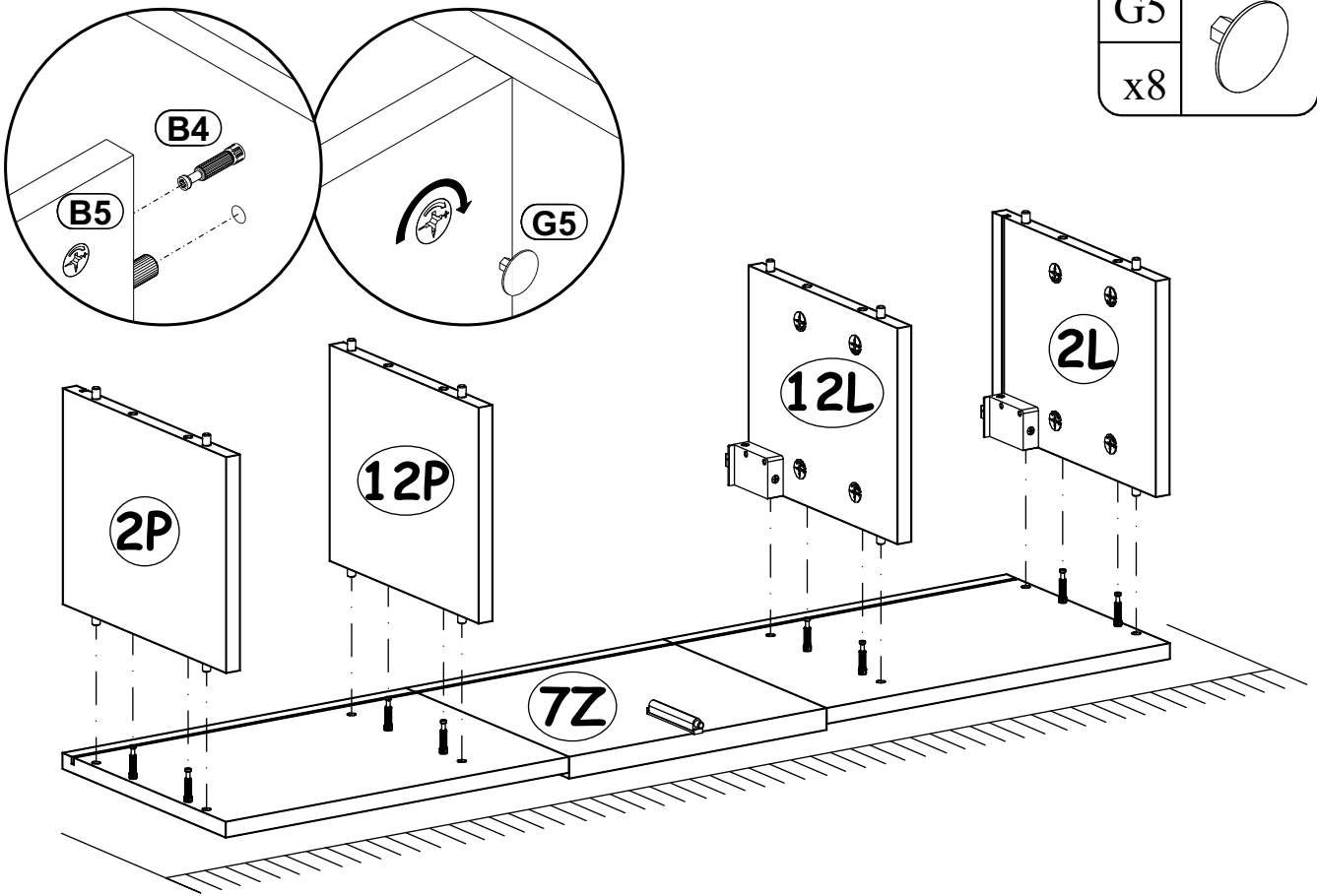

6

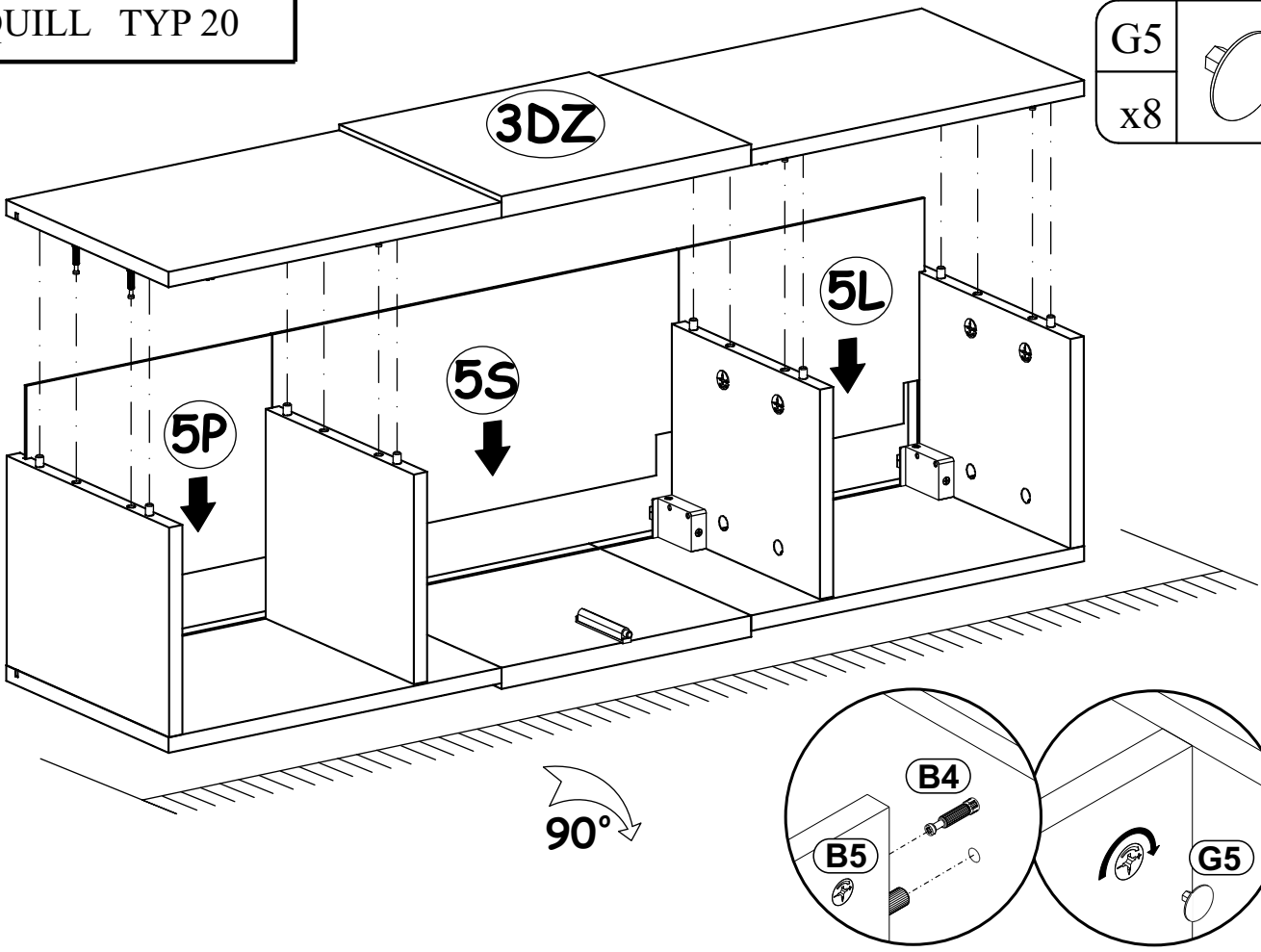

G5	
x8	

--	--

7

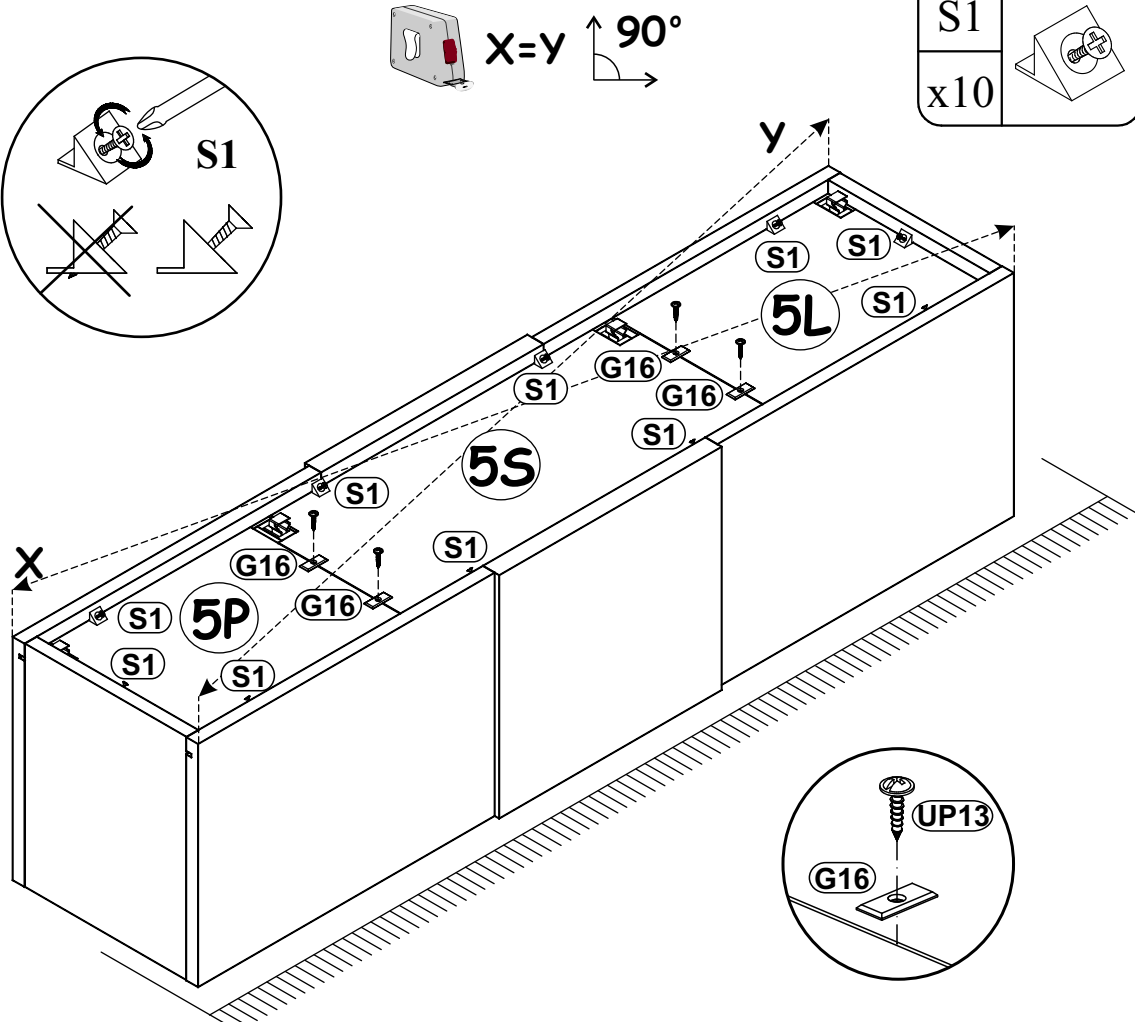

X=Y 90°

S1	
x10	

G16	
x4	

UP13	
x4	UPØ3x16

	UP13
	G16

QUILL TYP 20

8

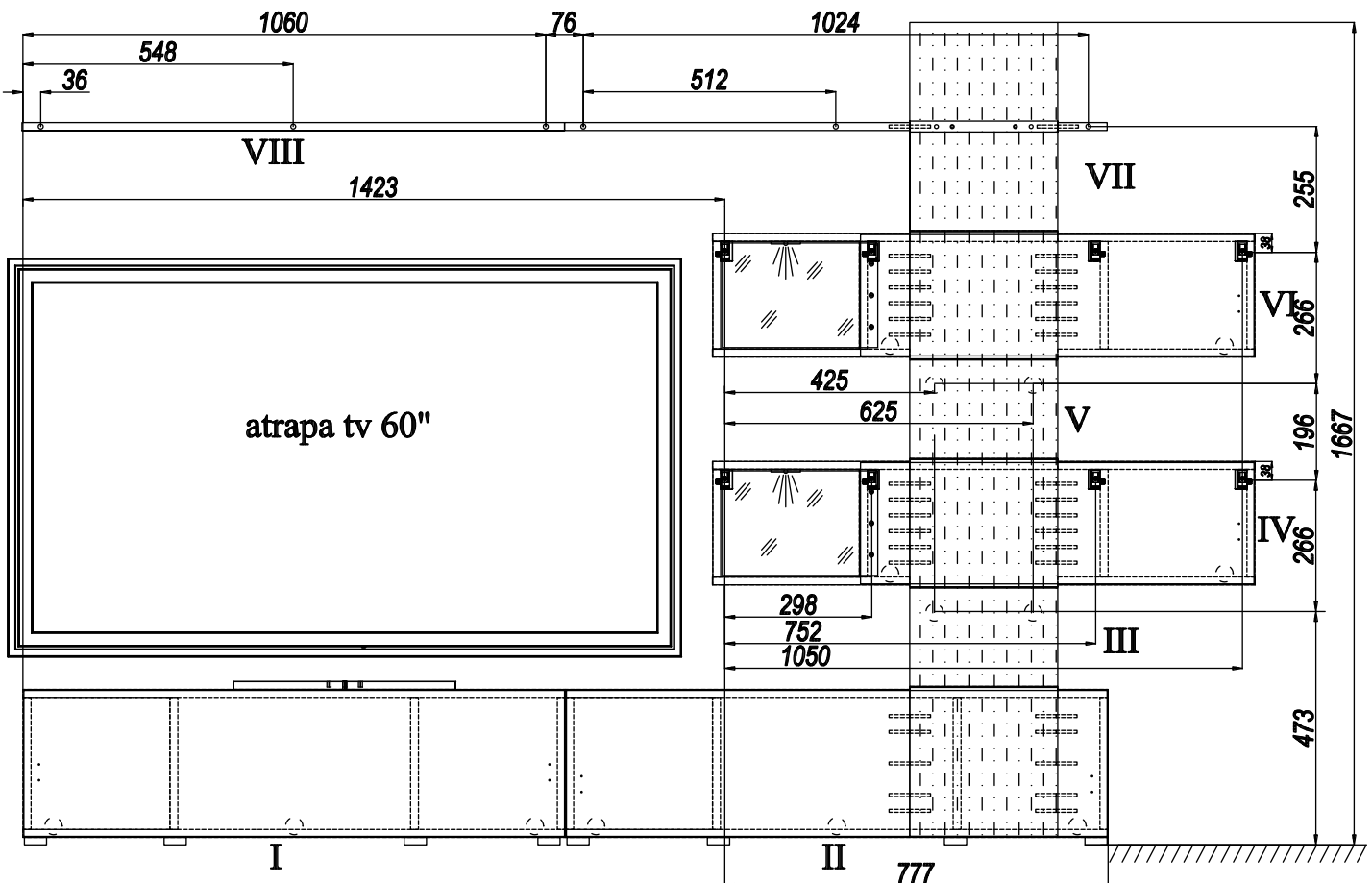
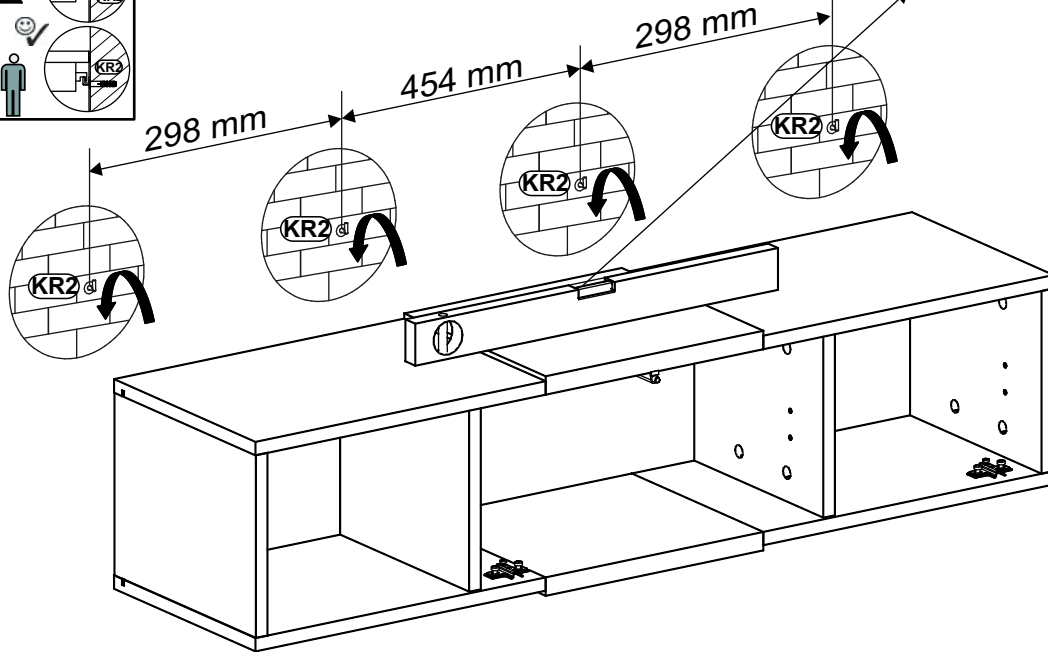
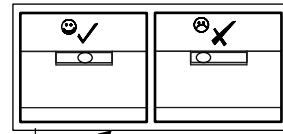
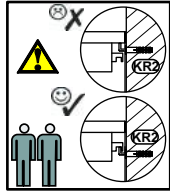
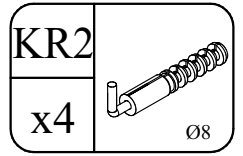
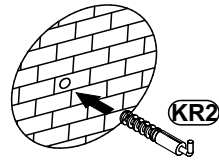
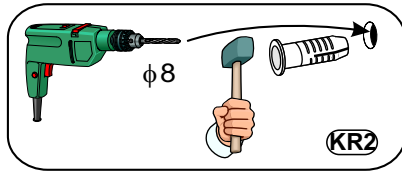
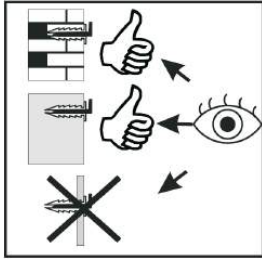

QUILL TYP 20

9

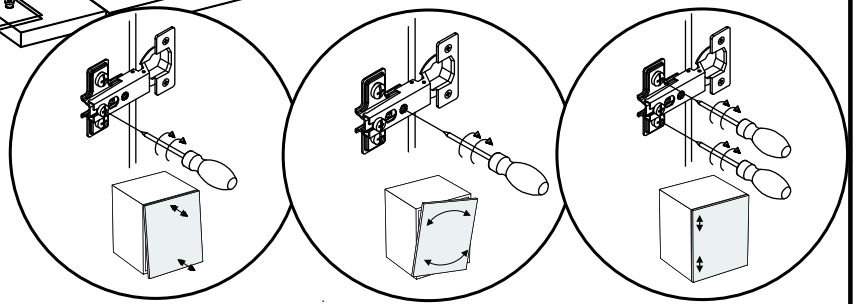
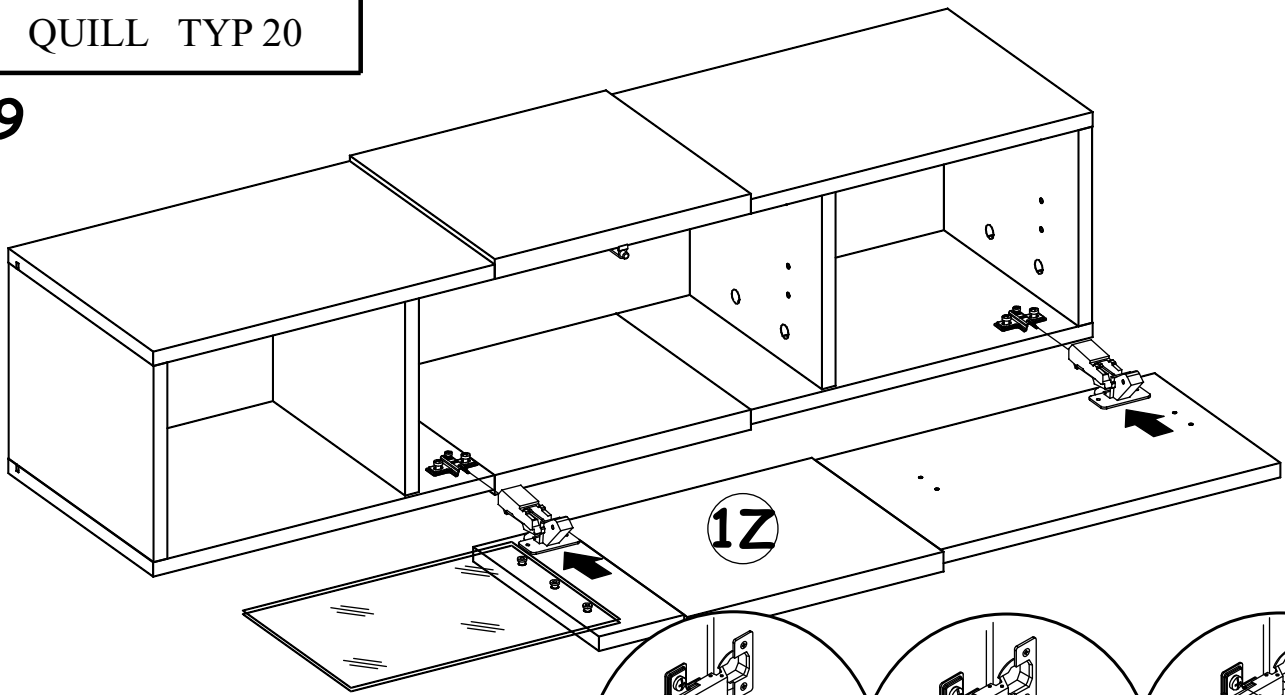

10

G21		D7		D10	
x2		x6	USØ3x16	X4	USØ3,5x13

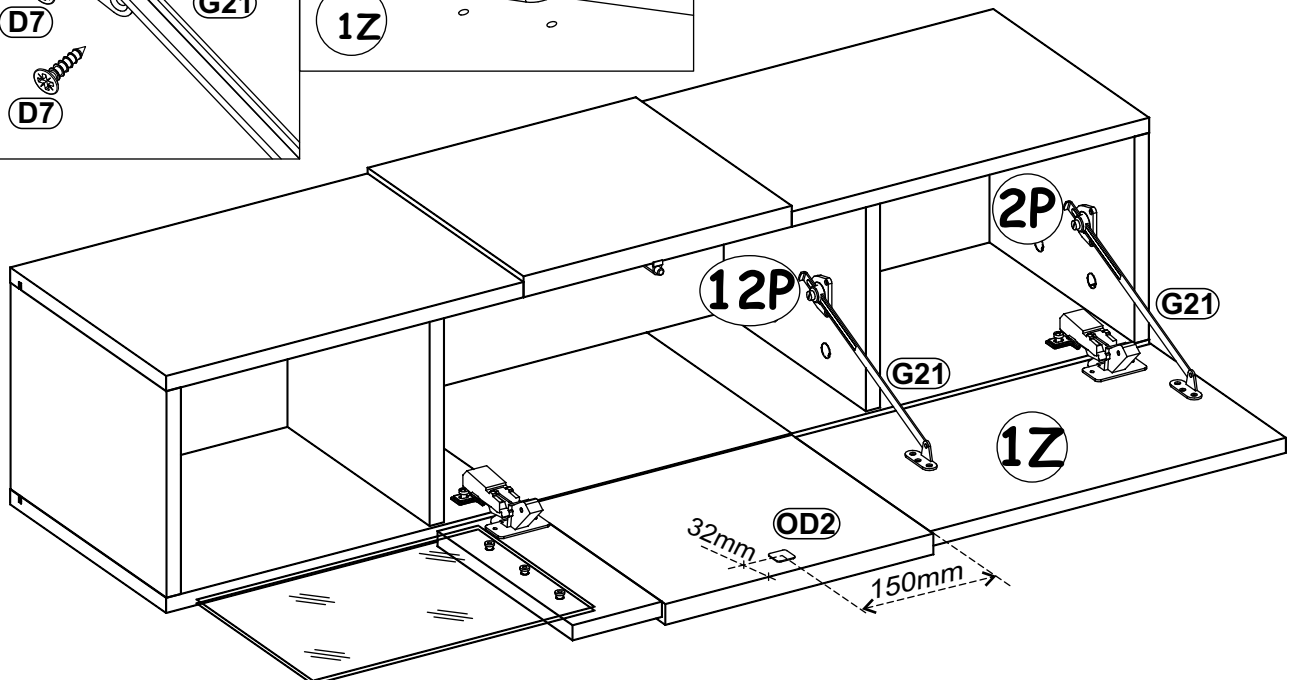
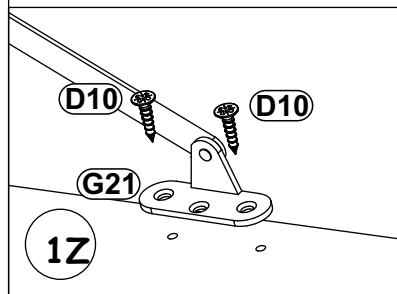
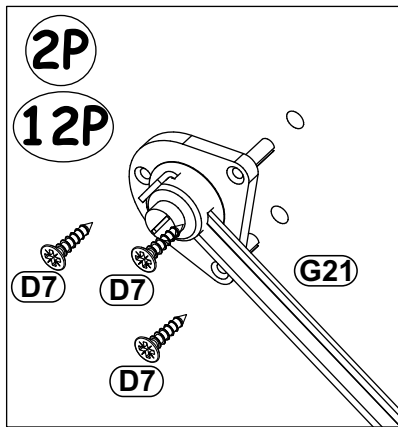

QUILL TYP 31

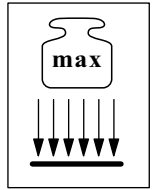
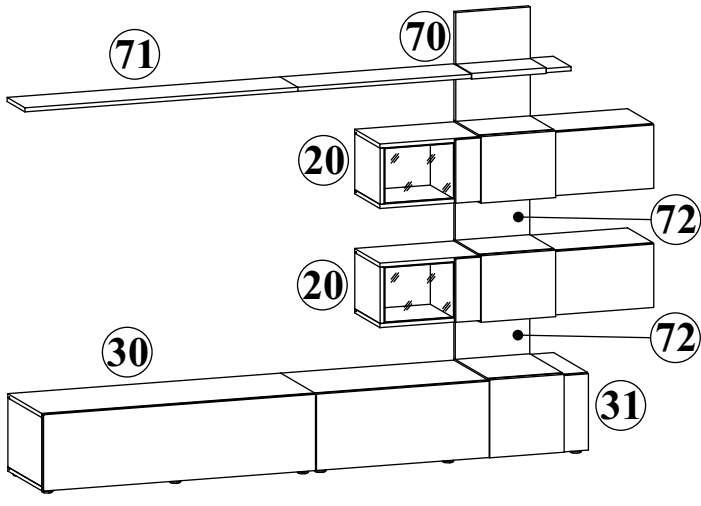

31

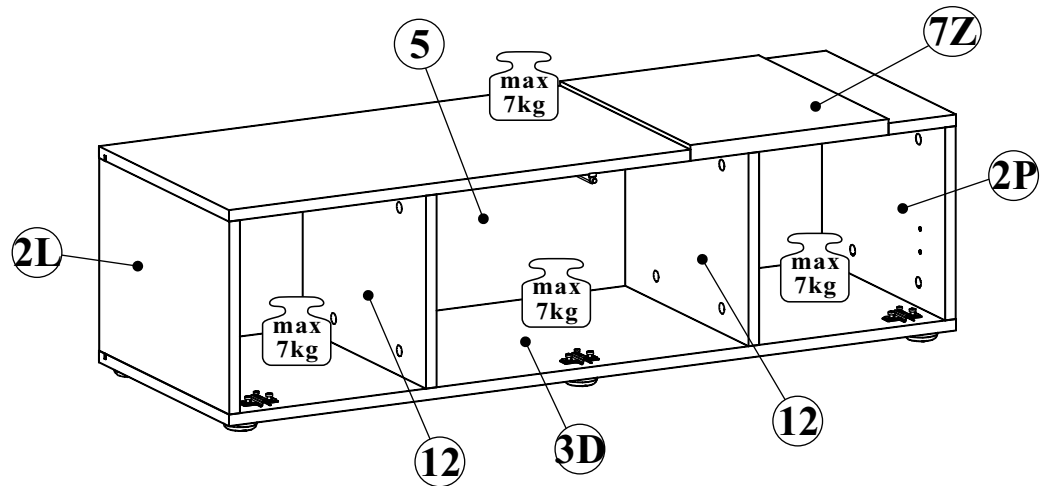
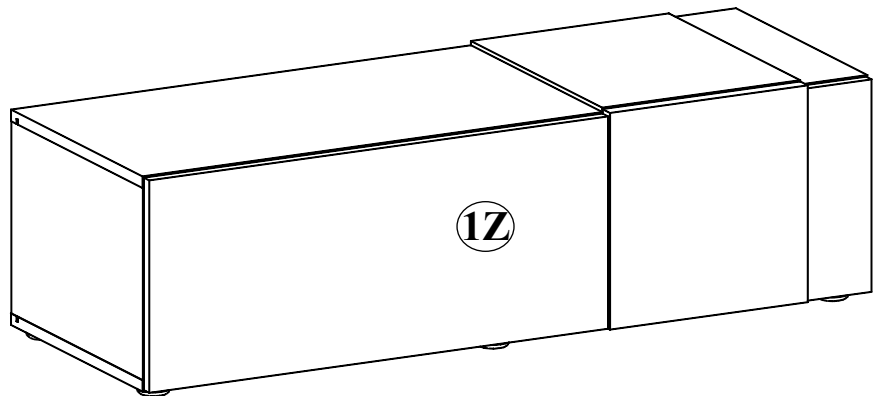



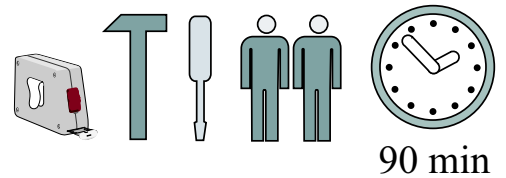





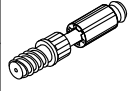

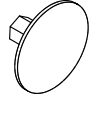

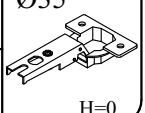
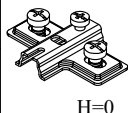
NO	Dim.			Col.-No	Qty
1Z	296	1096	16	1	1
2L	268	380	16	1	1
2P	268	380	16	1	1
12	268	360	16	1	2
3D	1100	380	16	1	1
5	280	1079	3	1	1
7Z	1100	380	16	1	1

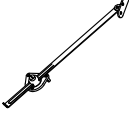

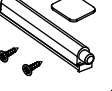
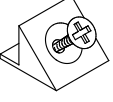
90 min

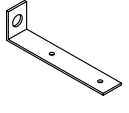

QUILL TYP 31

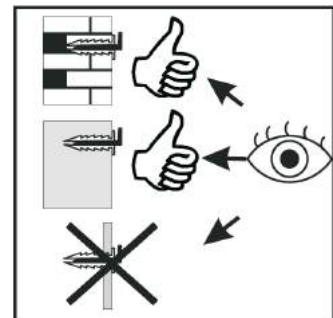
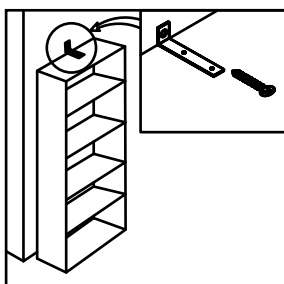
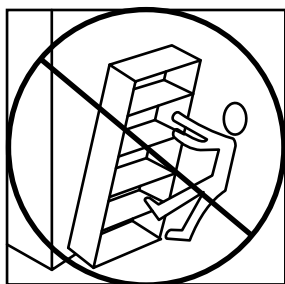
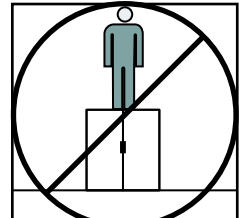
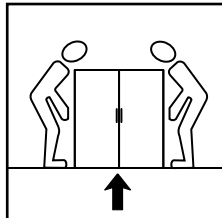
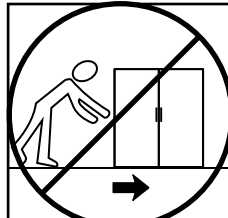
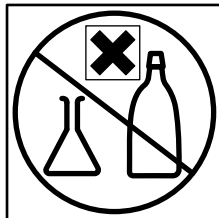
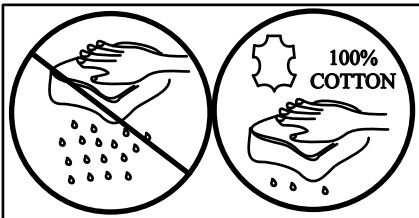
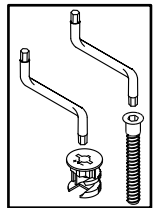
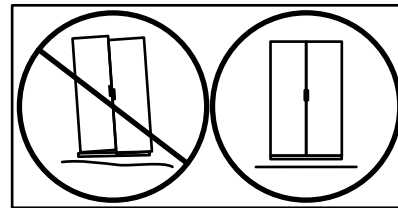
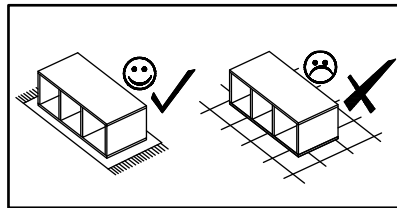
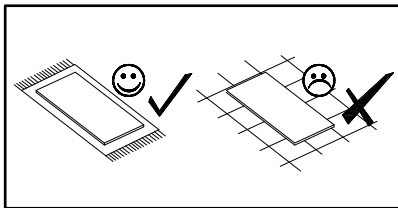
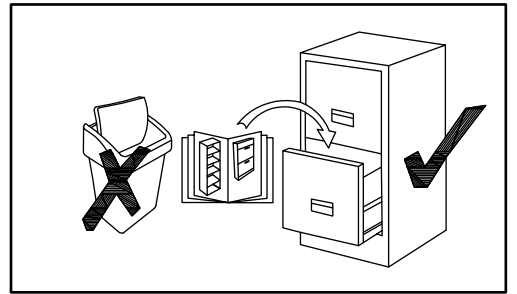
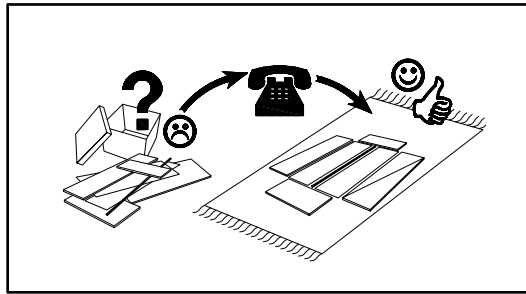
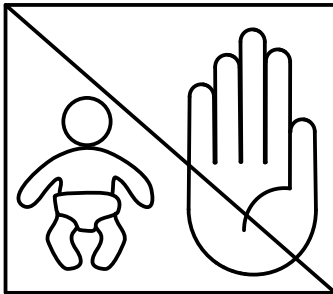
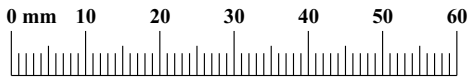
A1 x16  ø8x36	B4 x16 	B5 x16  Ø15x12	G5 x16 	I11 x6  Ø45, h=15	UP11 x6  UPØ4x20
E21 x3  Ø35 H=0	E2 x3  H=0	D10 x14  USØ3,5x13	G21 x2 	D7 x6  USØ3x16	OD2 x1 
S1 x10 	UP13 x2  UPØ3x16	KR1 x1 	L1 x1 	G2 x1 	



QUILL TYP 31

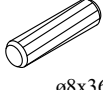

1

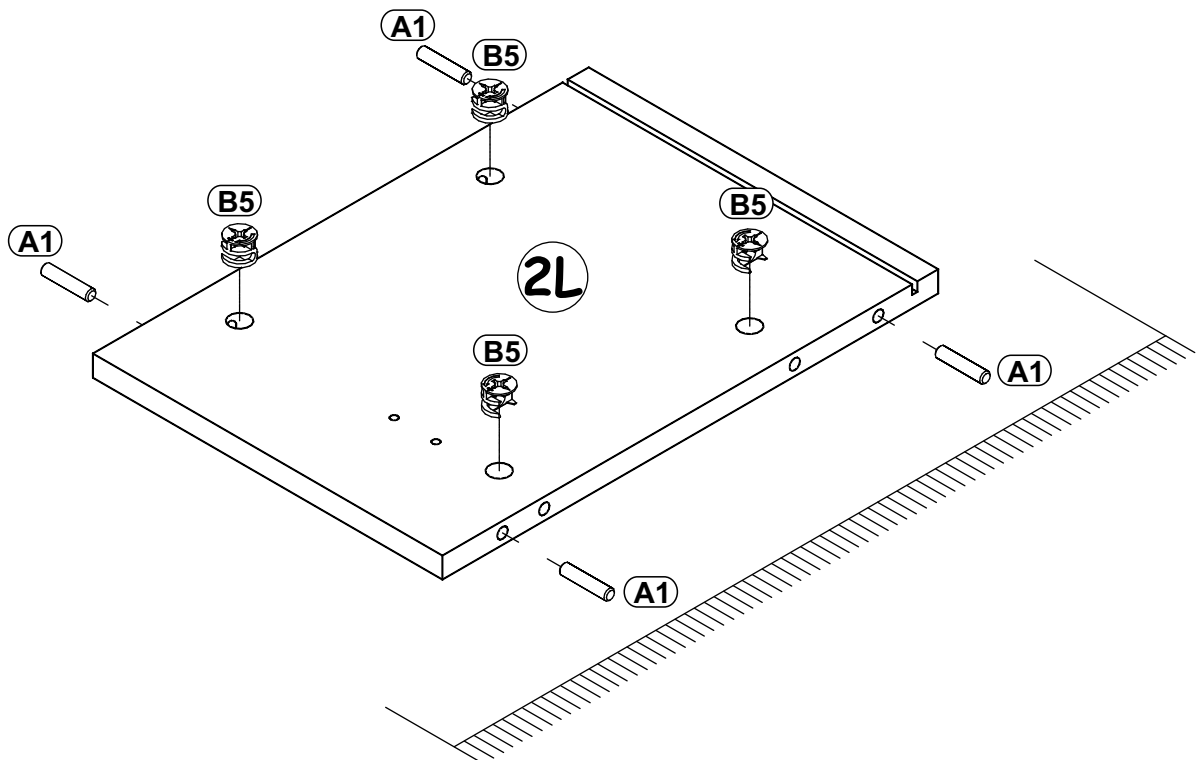
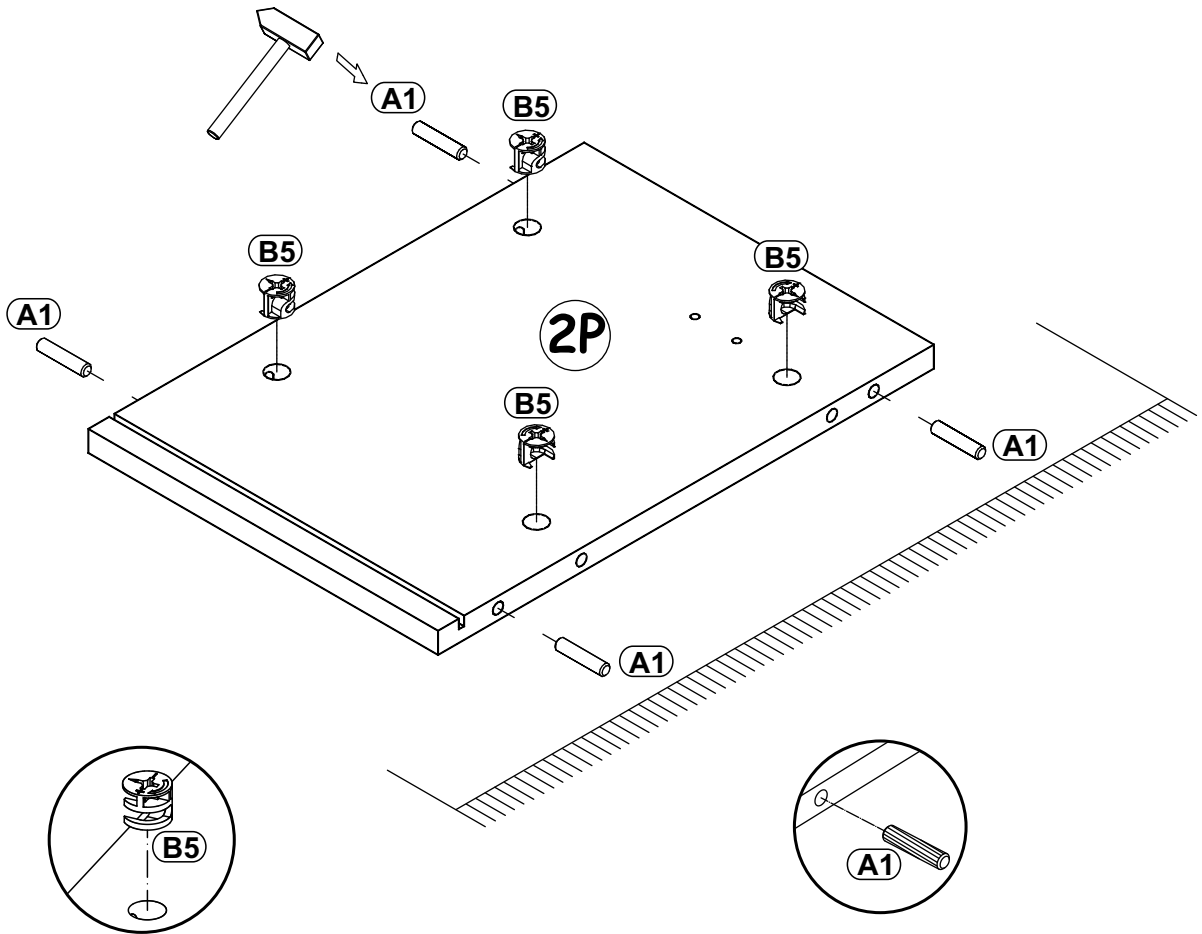
A1	 ø8x36	B5	 Ø15x12
x8		x8	

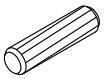

QUILL TYP 31

2

A1		B5	
x8	ø8x36	x8	Ø15x12

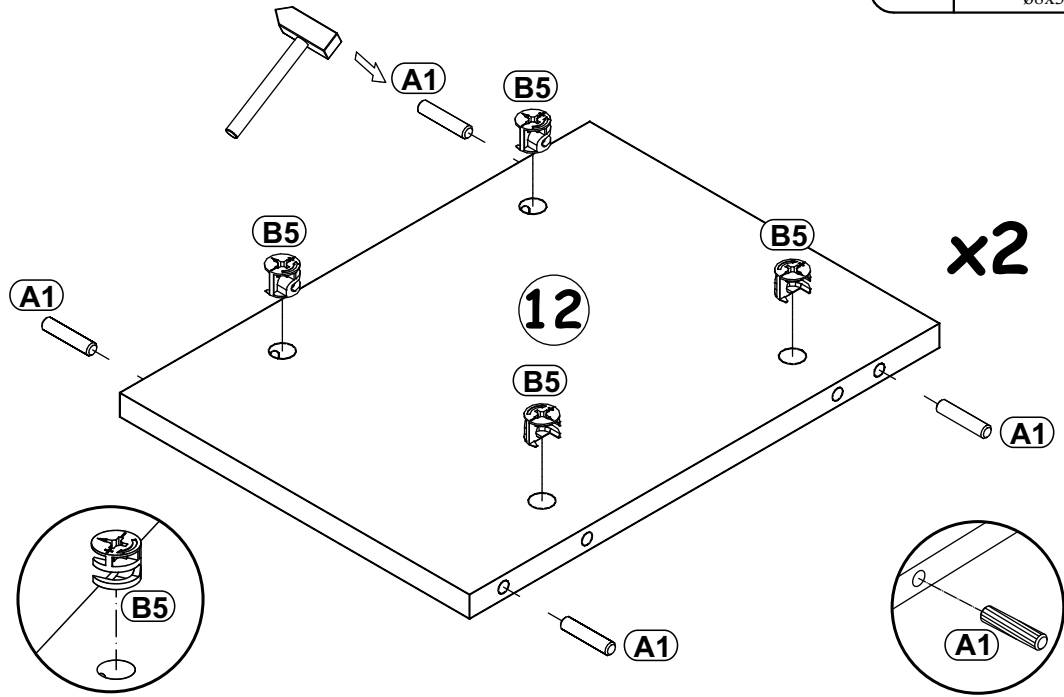

3

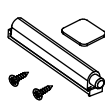
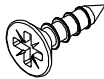
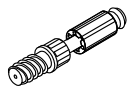
OD2		D10		B4	
x1		x2	USØ3,5x13	x8	

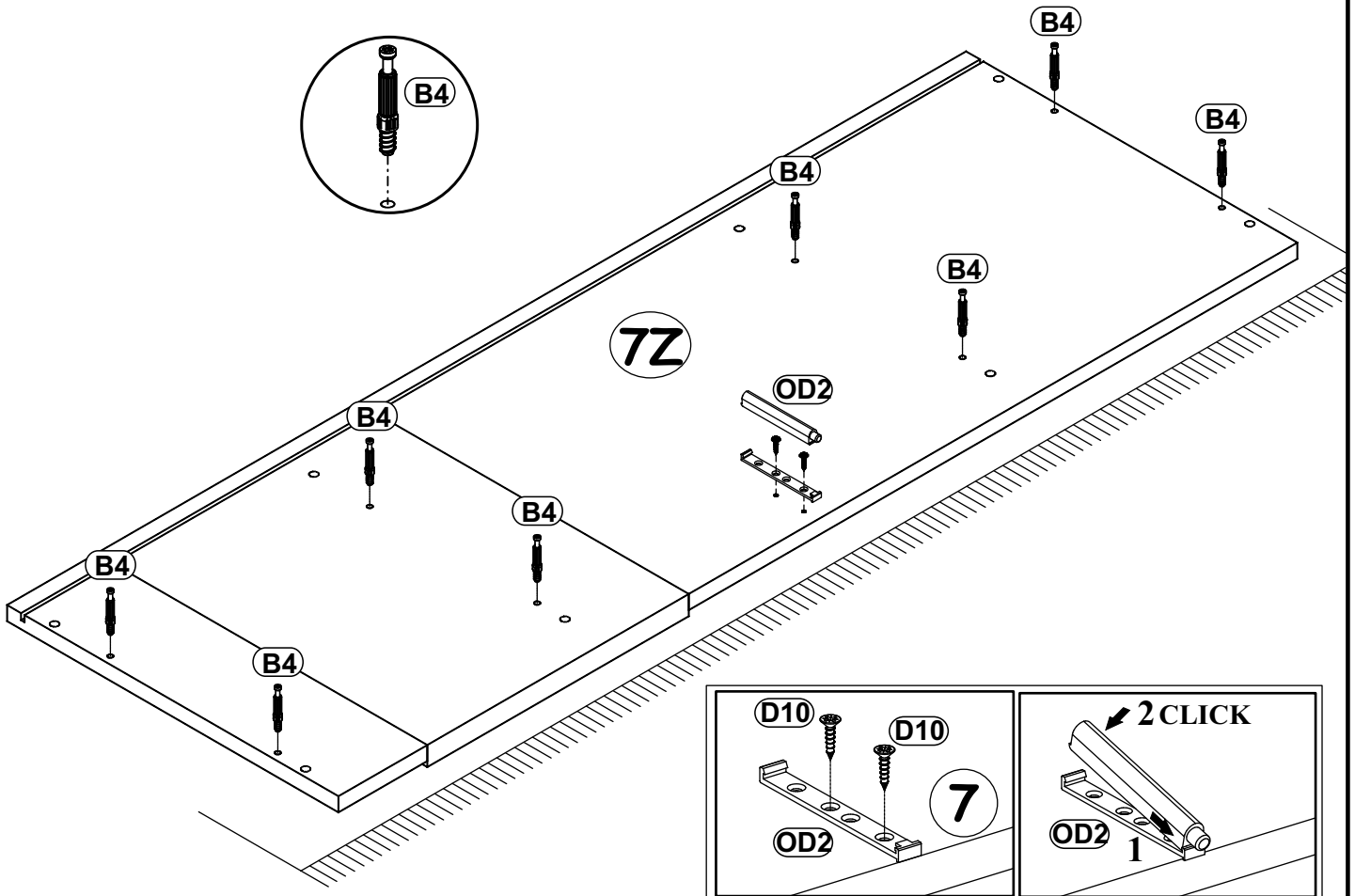

QUILL TYP 31

4

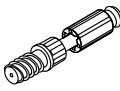
B4	
x8	

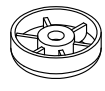
I11	
x6	Ø45, h=15

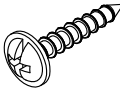
UP11	
x6	UPØ4x20

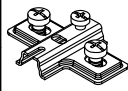
E2	
x3	H=0

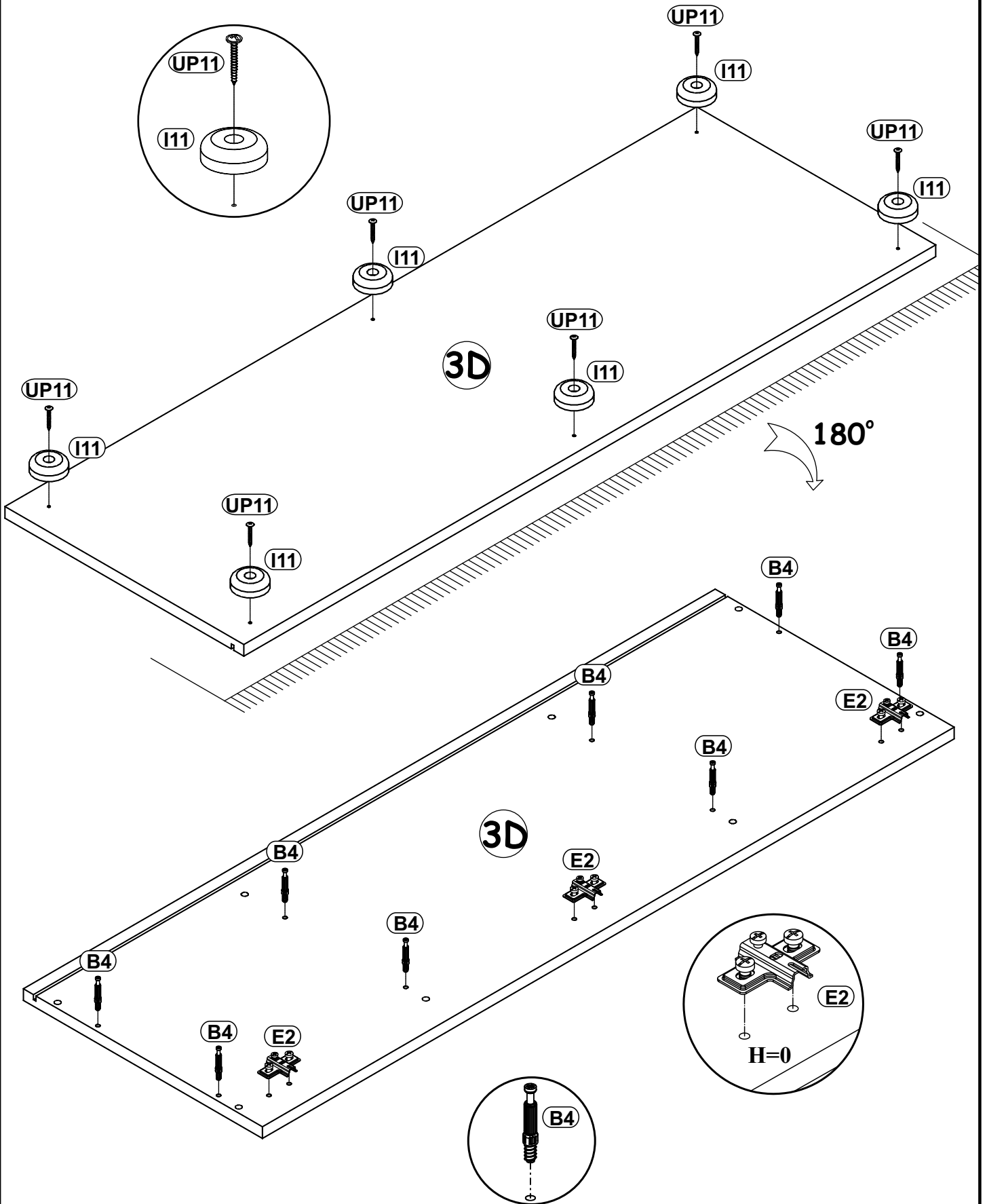

QUILL TYP 31

5

E21	Ø35	D10	 USØ3,5x13
x3	H=0	x6	

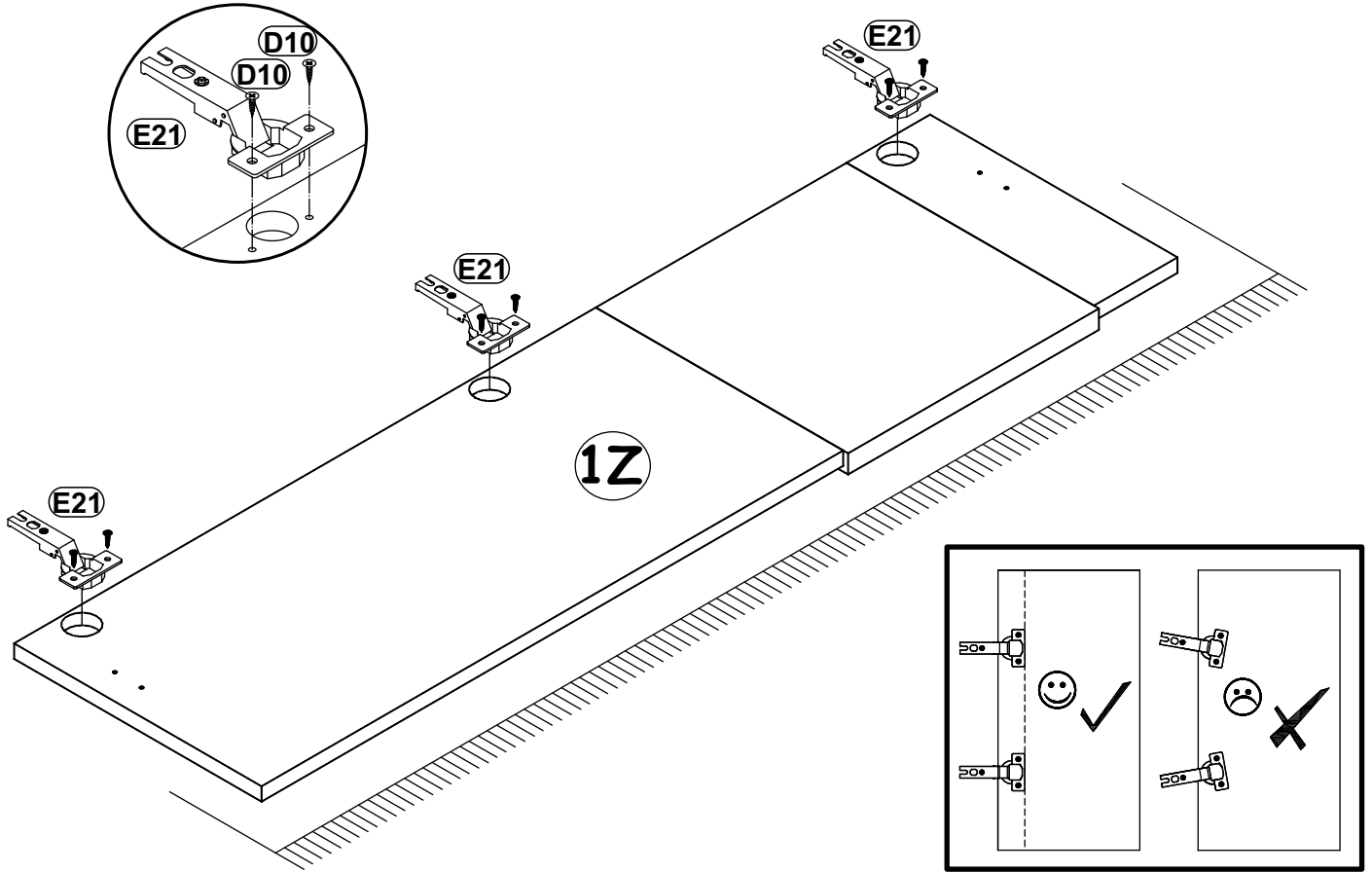

6

G5	
x8	

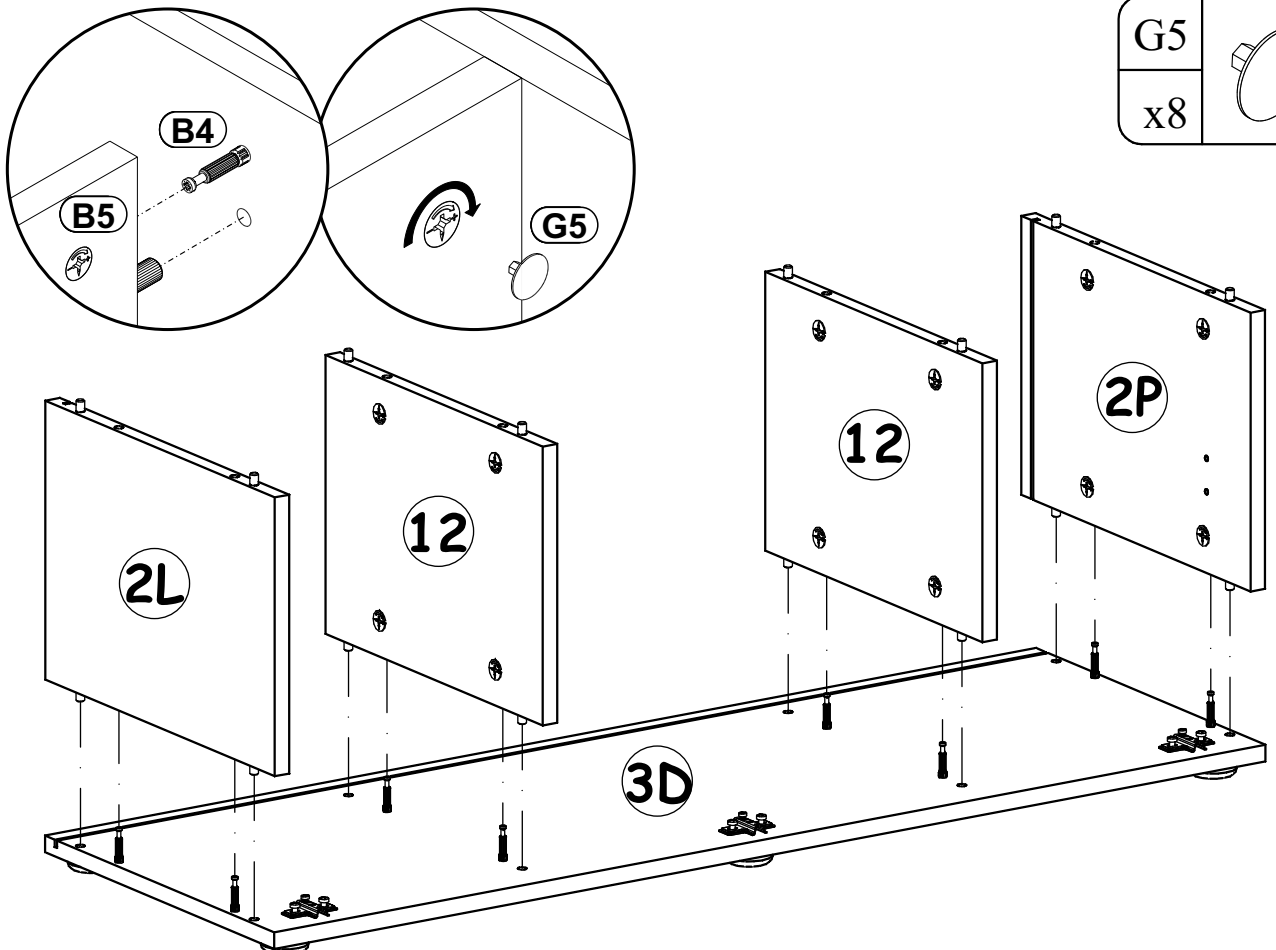

QUILL TYP 31

7

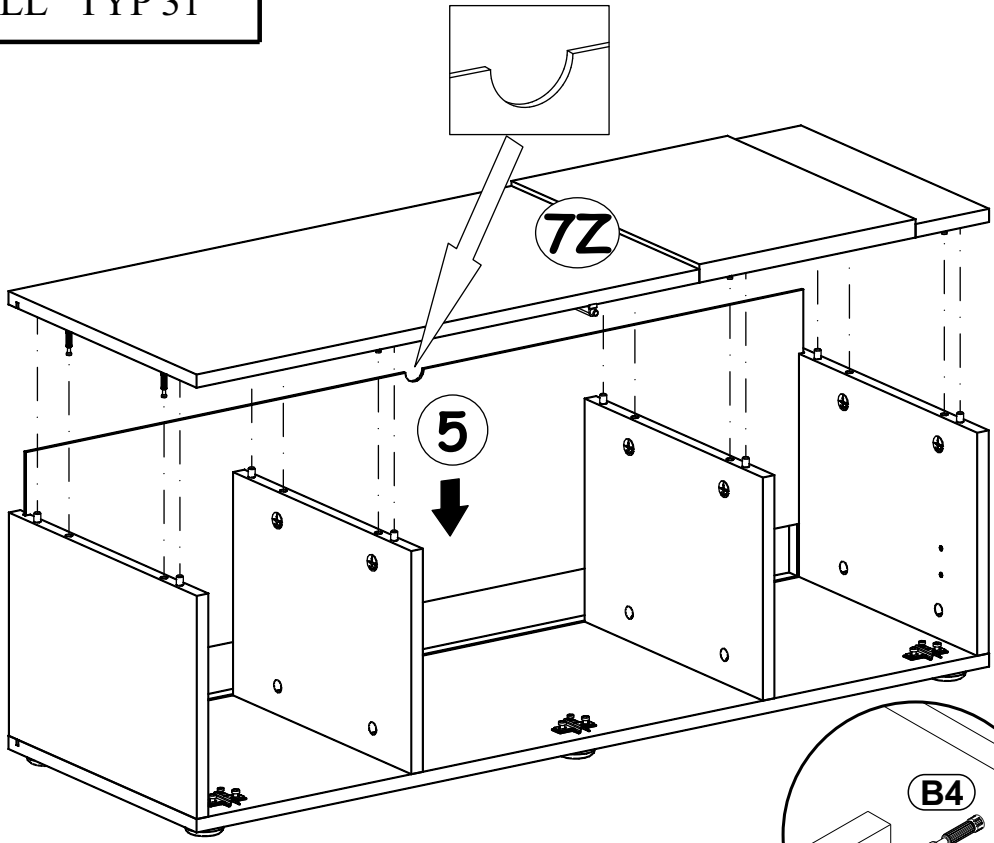

G5	
x8	

8

S1	
x10	

UP13	
x2	UPØ3x16

X=Y

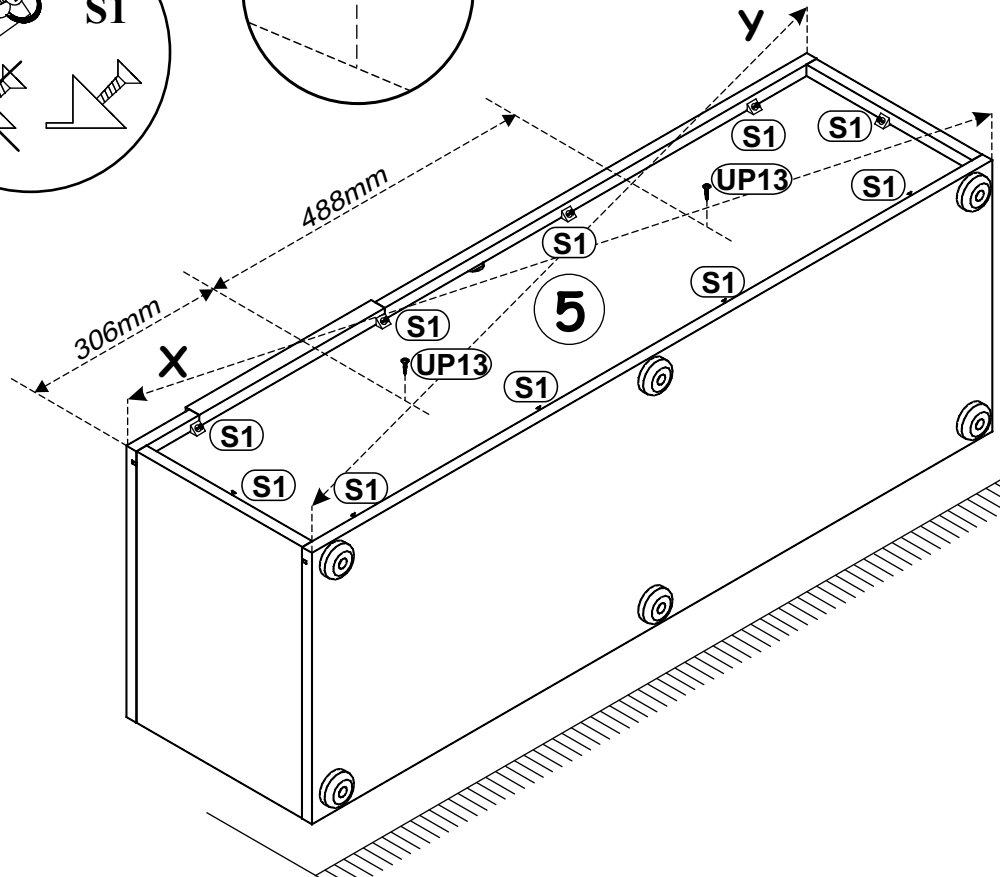

QUILL TYP 31

9

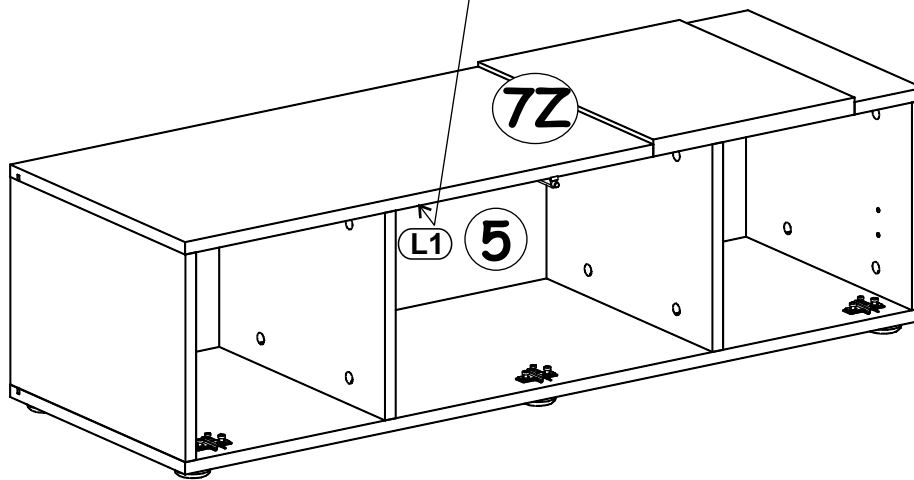
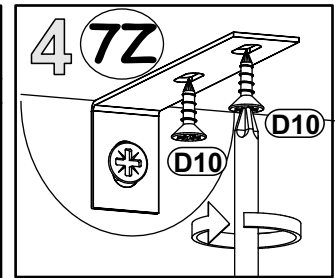
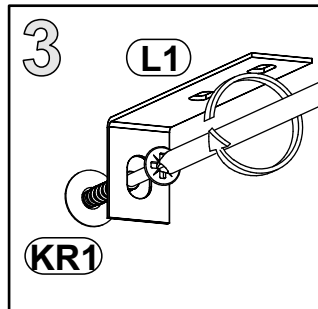
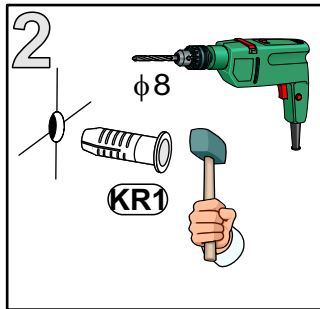
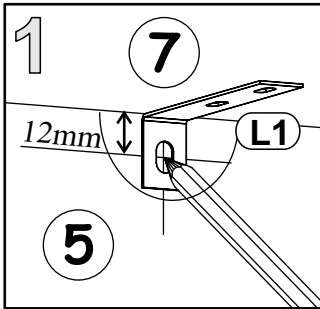
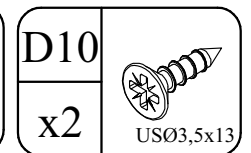
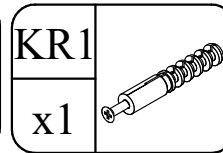
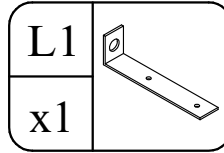
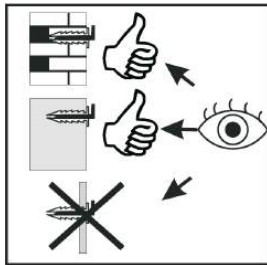

10

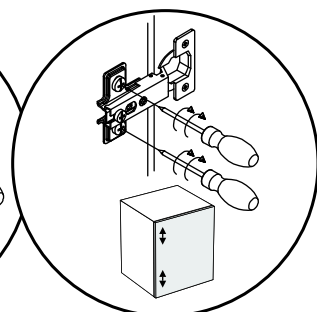
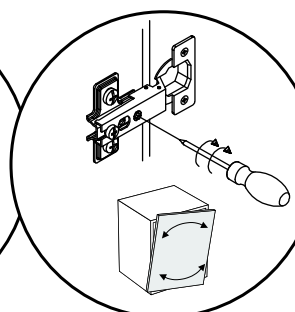
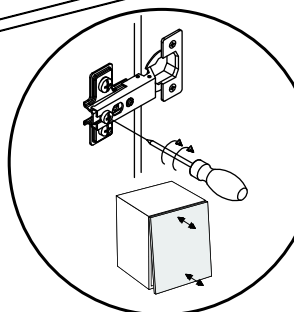
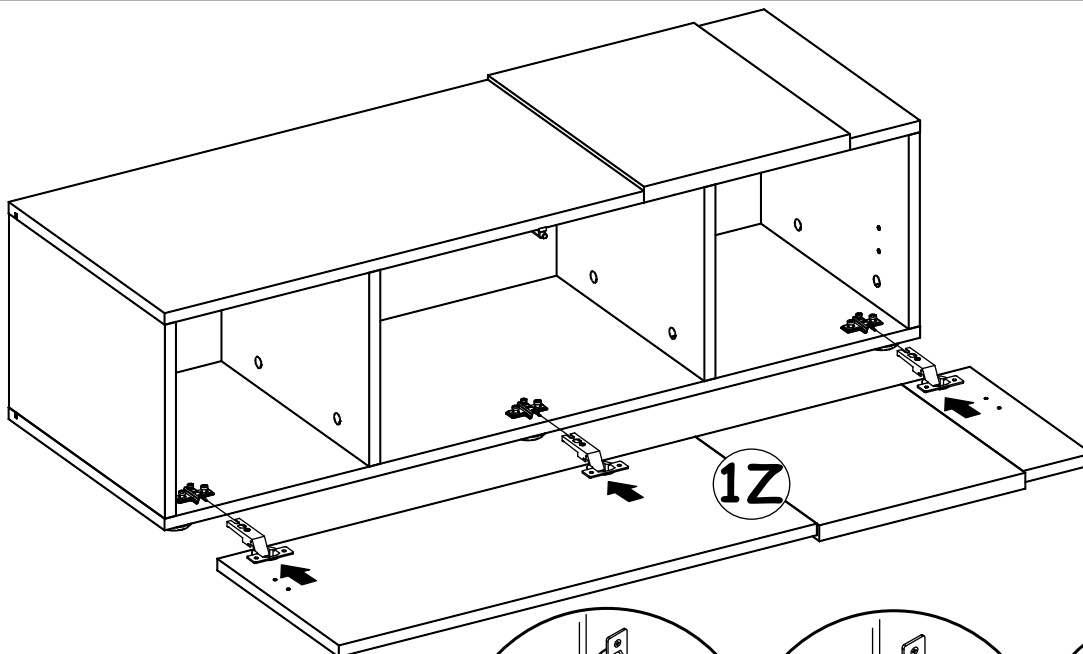

QUILL TYP 31

11

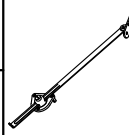
G21	
x2	

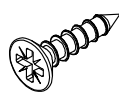
D7	
x6	USØ3x16

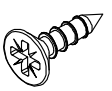
D10	
X4	USØ3,5x13

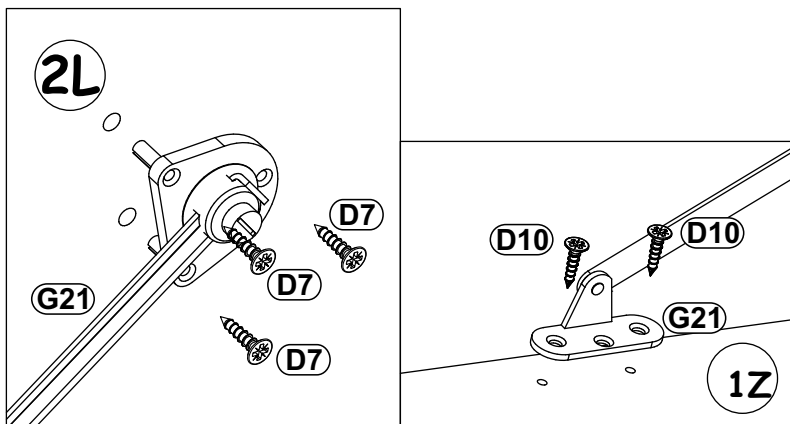
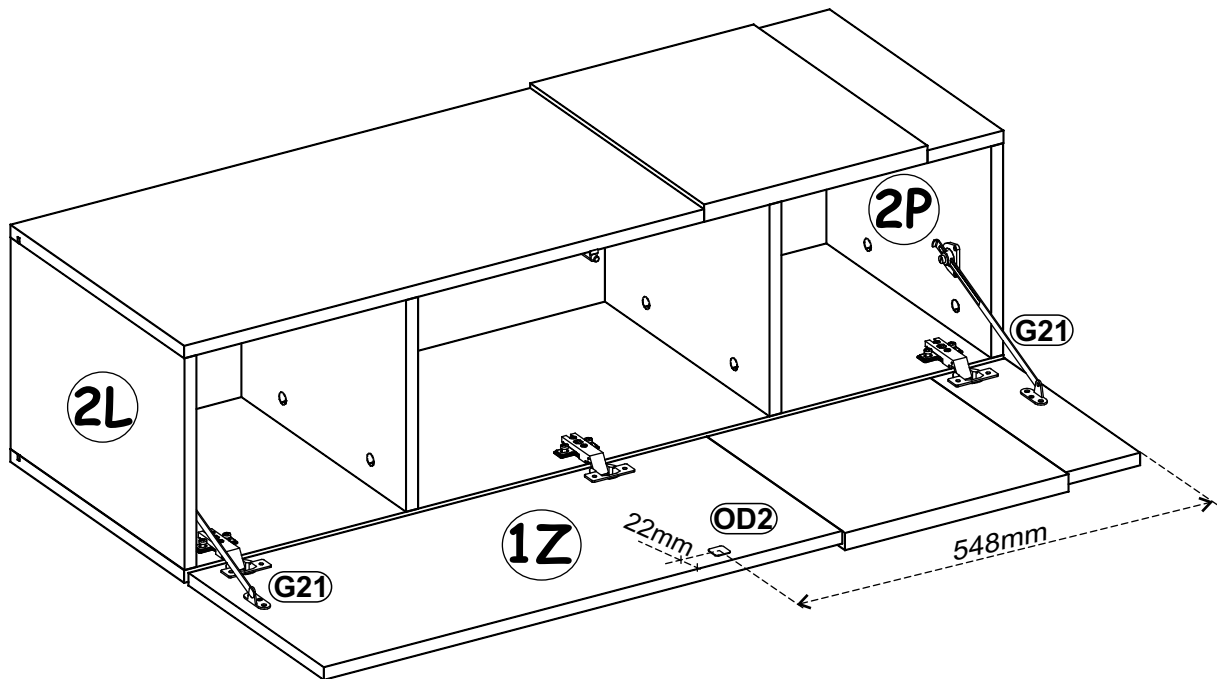
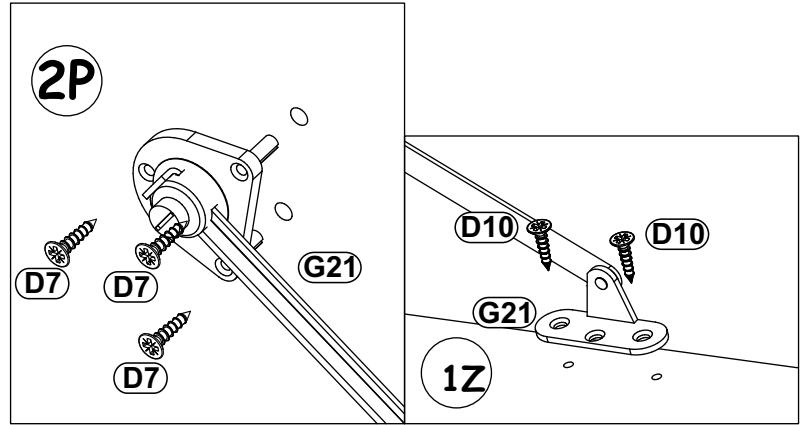

QUILL TYP 70; 71; 72

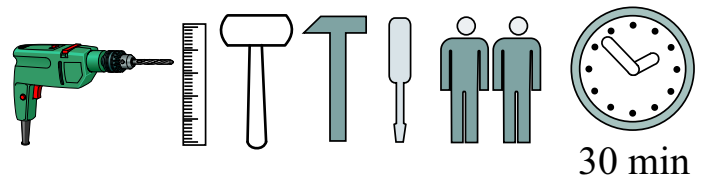
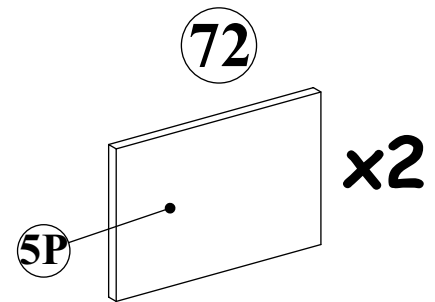
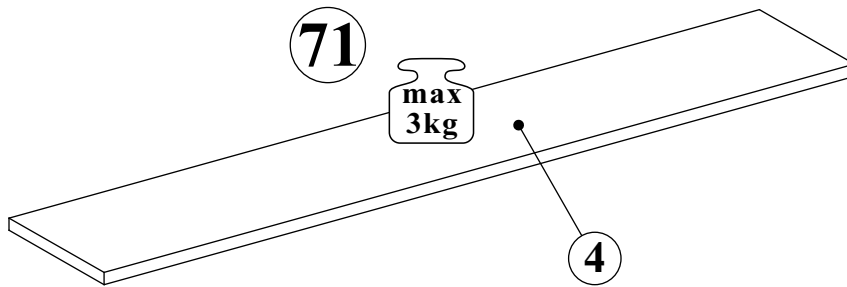
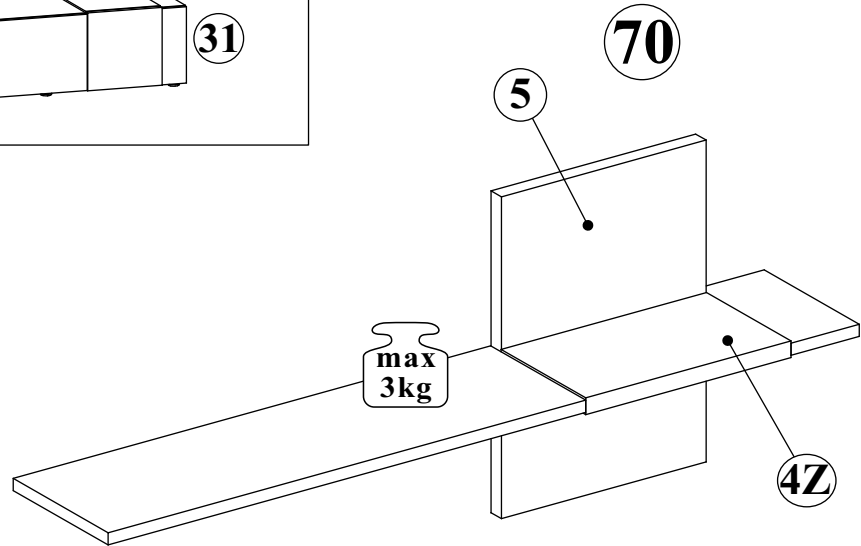
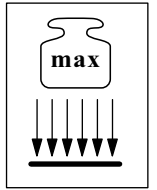
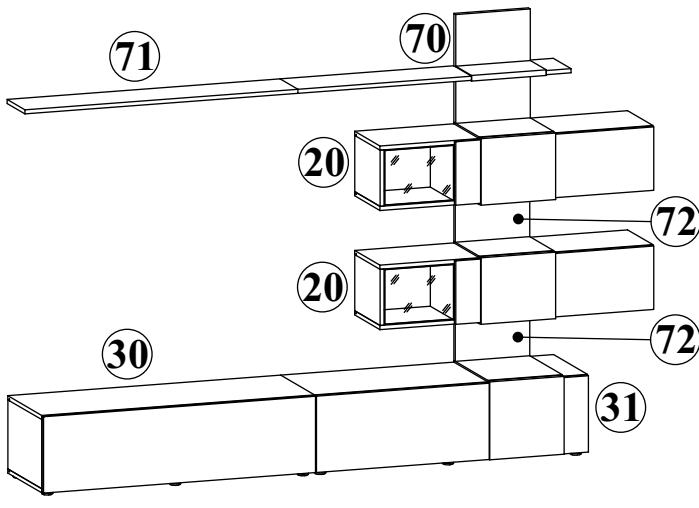

NO	Dim.			Col.-No	Qty
5P	200	300	22	1	2
5	422	300	22	1	1
4Z	1100	200	16	1	1
4	1100	200	16	1	1

QUILL TYP 70; 71; 72

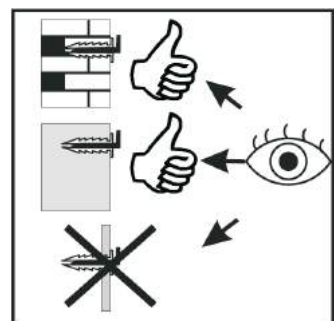
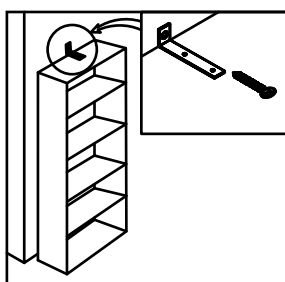
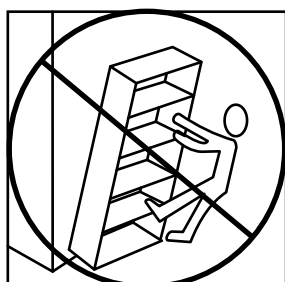
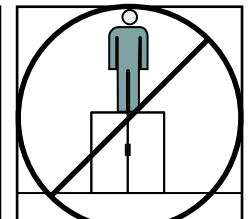
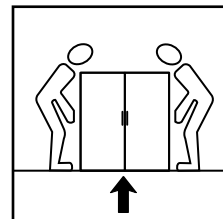
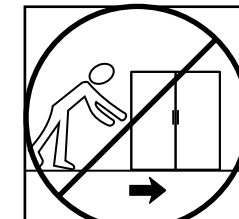
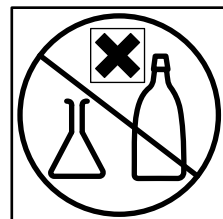
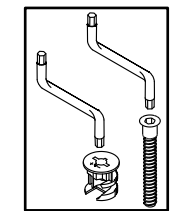
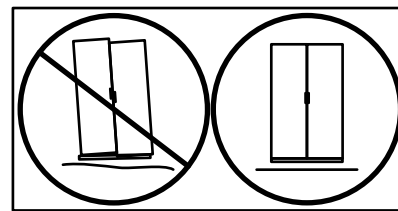
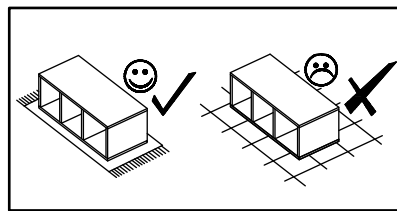
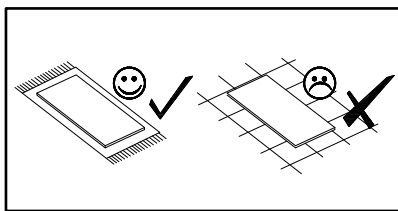
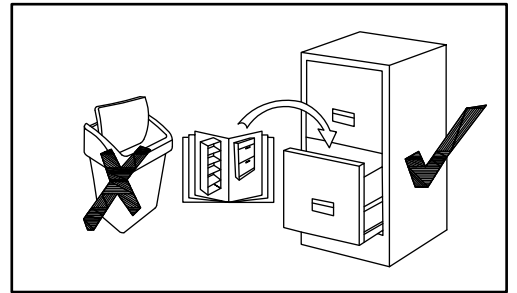
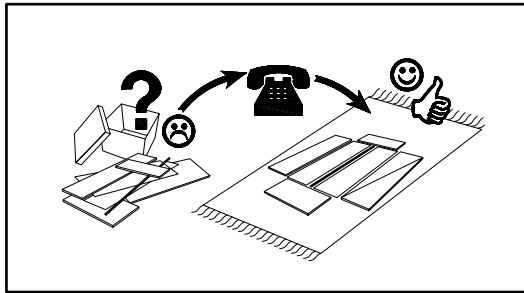
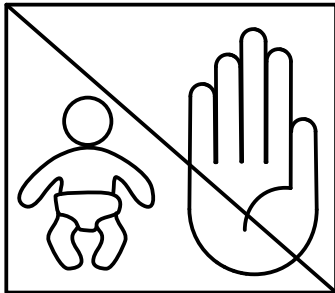
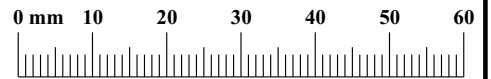
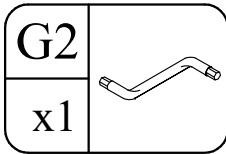
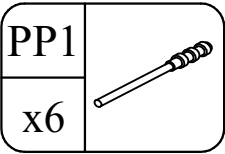
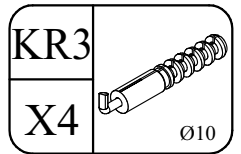
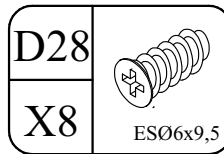
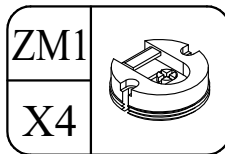
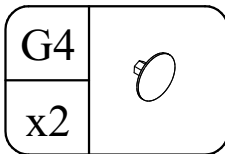
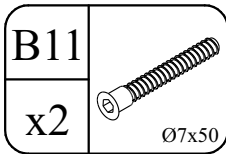
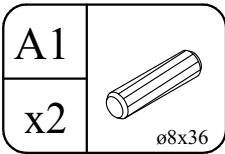

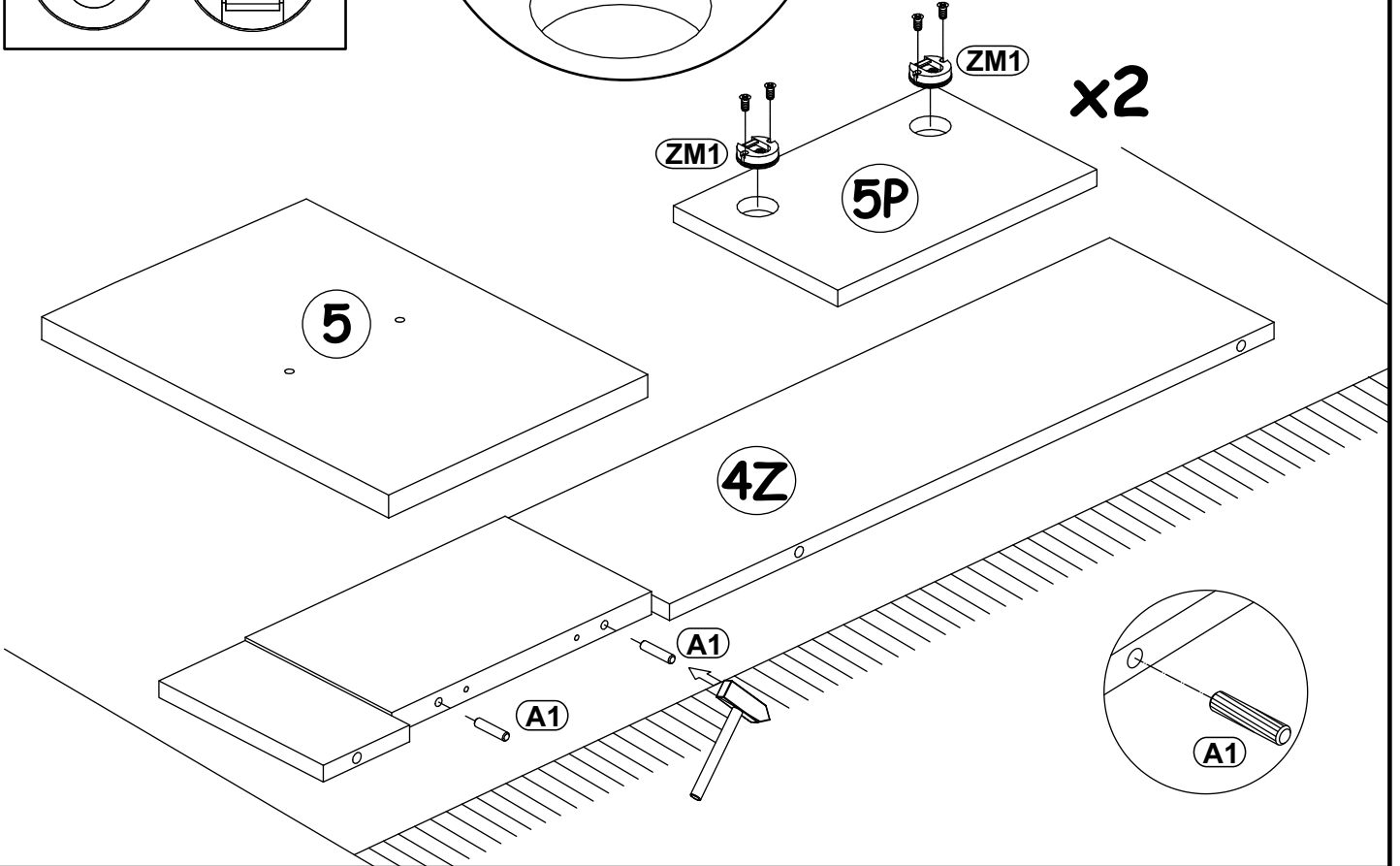
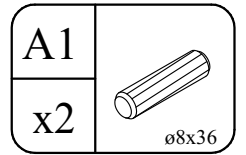
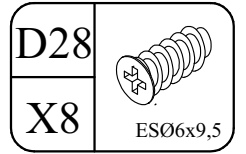
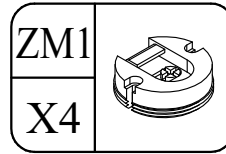
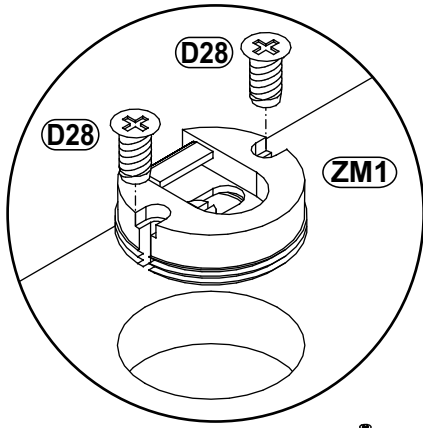
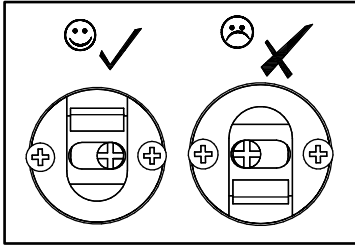

QUILL TYP 70; 71; 72

1

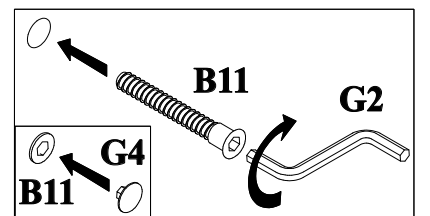
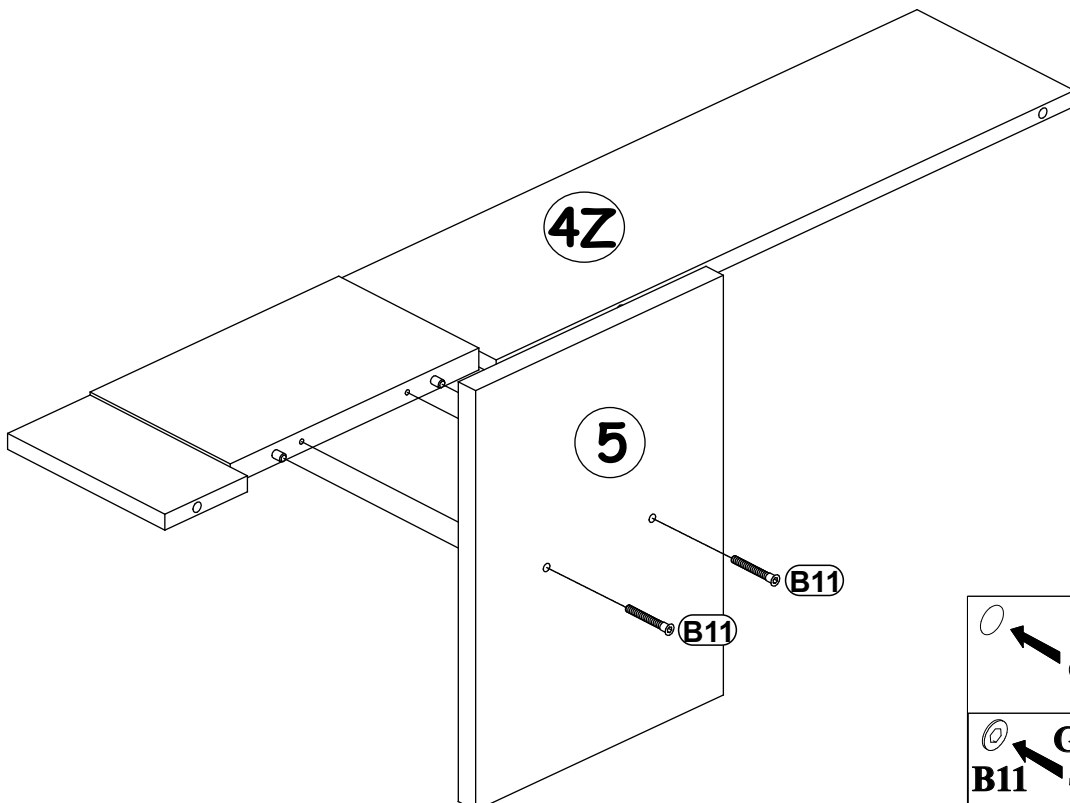
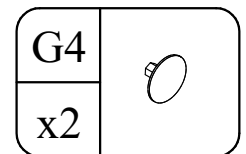
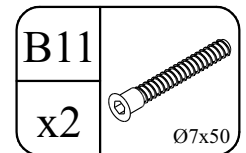

2

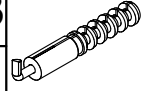

KR3		PP1	
x6	Ø10	x6	

3

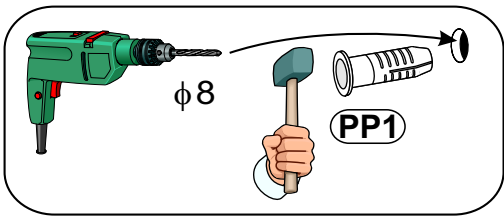
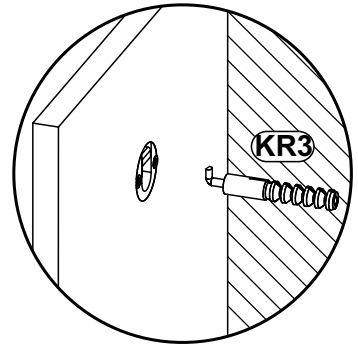
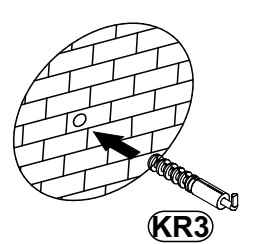
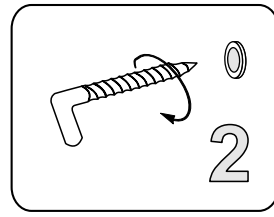
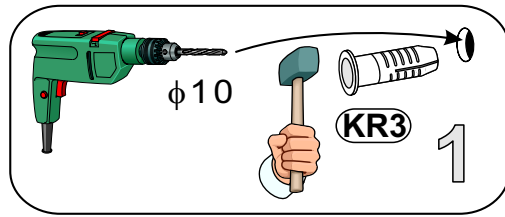
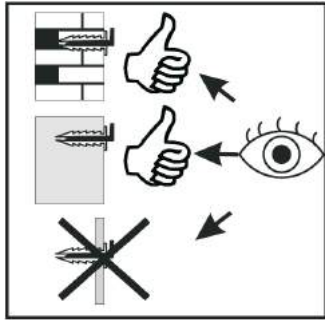

IV

III

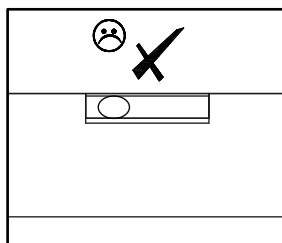
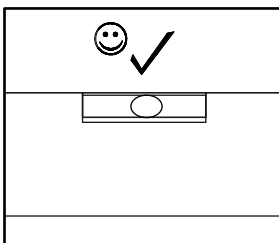
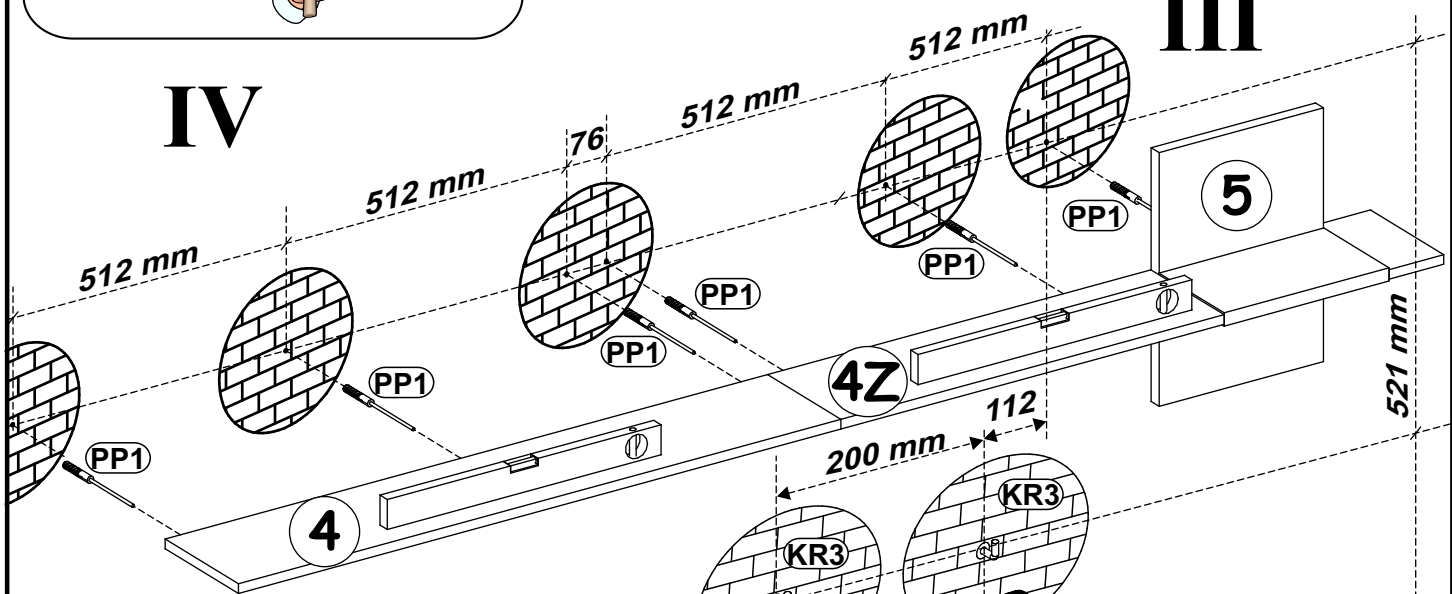

II

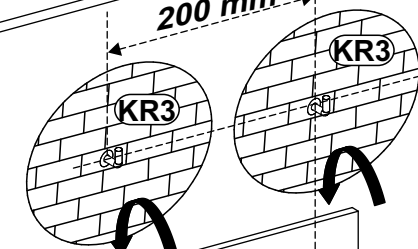

I

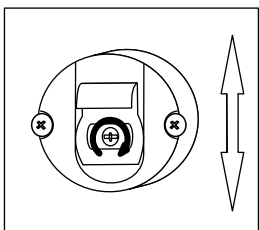
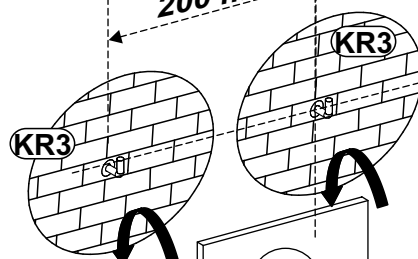

31

QUILL TYP 30

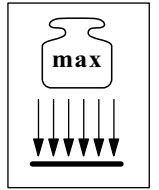
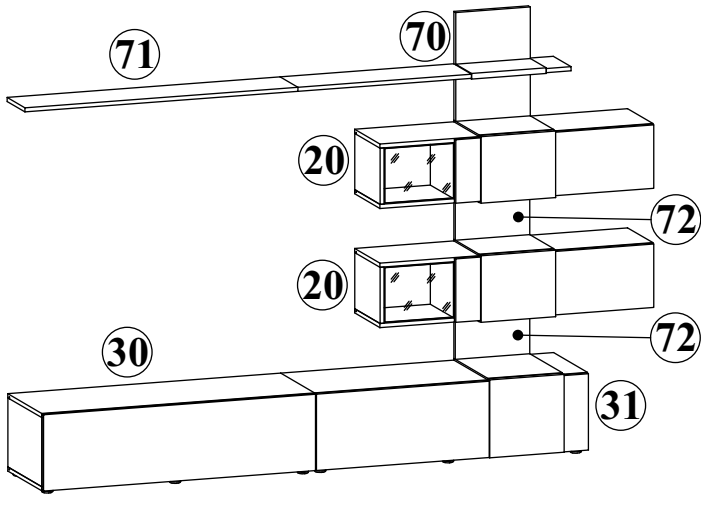

30

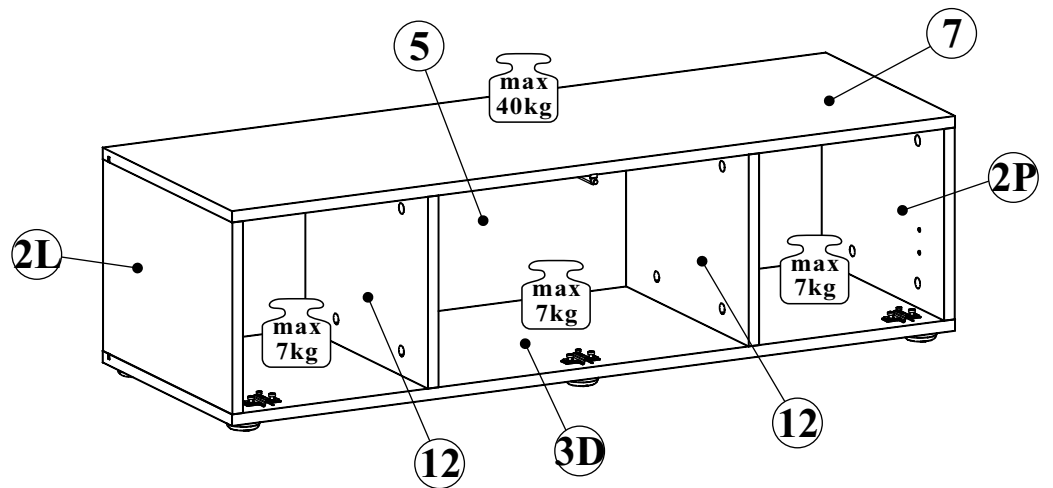
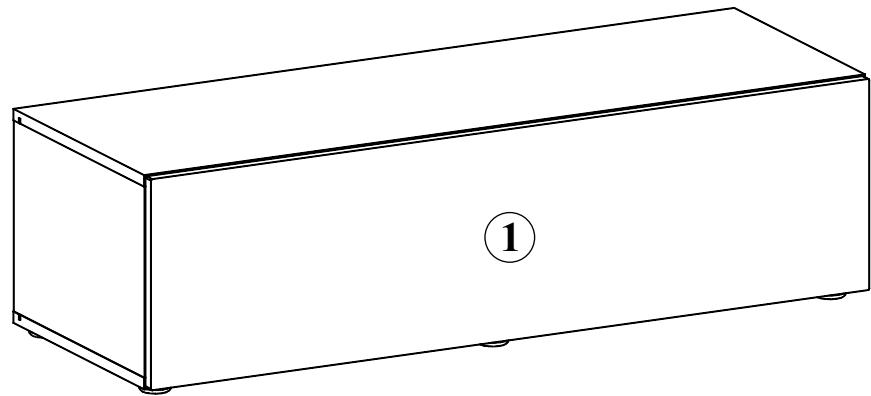



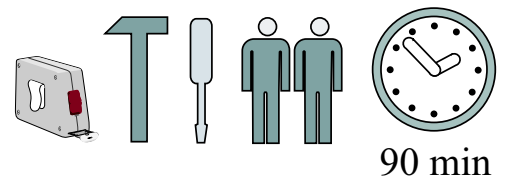





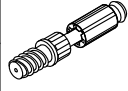

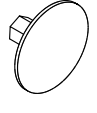

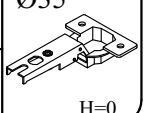
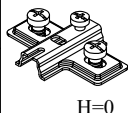
NO	Dim.		Col.-No	Qty
1	296	1096	16	1
2L	268	380	16	1
2P	268	380	16	1
12	268	360	16	2
3D	1100	380	16	1
5	280	1079	3	1
7	1100	380	16	1

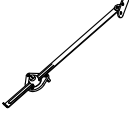

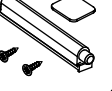
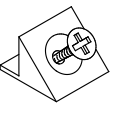
90 min

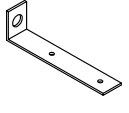
QUILL TYP 30

A1 x16  ø8x36	B4 x16 	B5 x16  Ø15x12	G5 x16 	I11 x6  Ø45, h=15	UP11 x6  UPØ4x20
E21 x3  Ø35 H=0	E2 x3  H=0	D10 x14  USØ3,5x13	G21 x2 	D7 x6  USØ3x16	OD2 x1 
S1 x10 	UP13 x2  UPØ3x16	KR1 x1 	L1 x1 	G2 x1 	

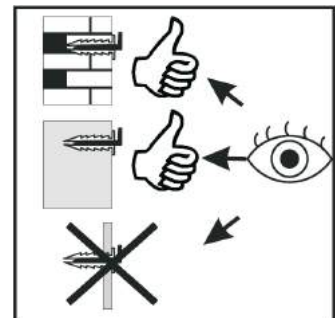
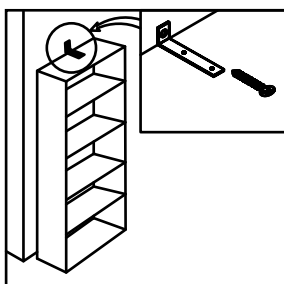
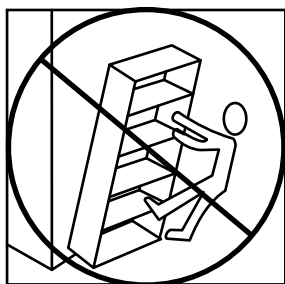
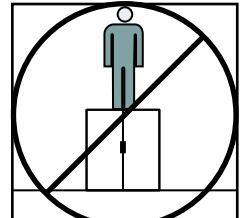
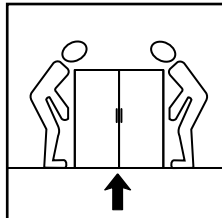
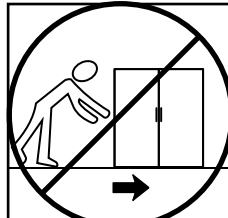
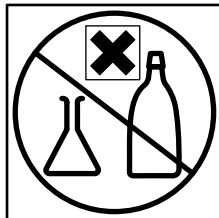
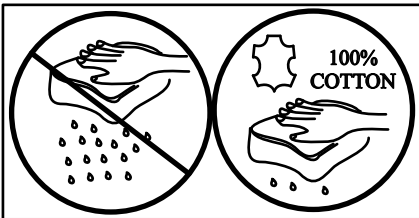
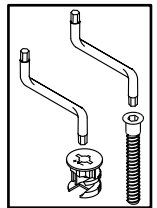
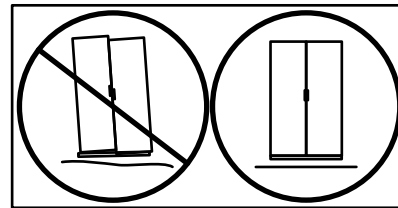
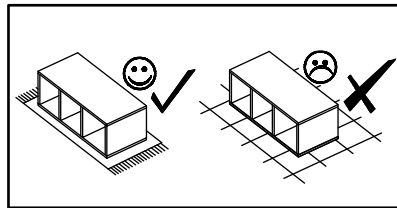
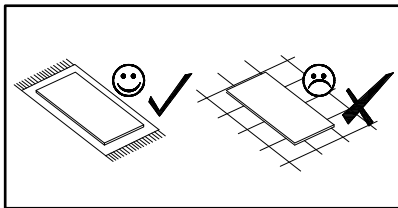
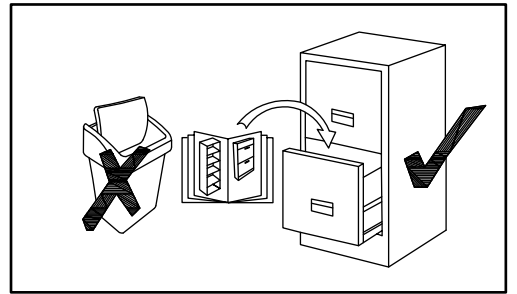
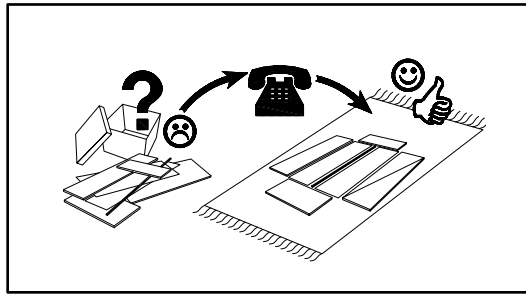
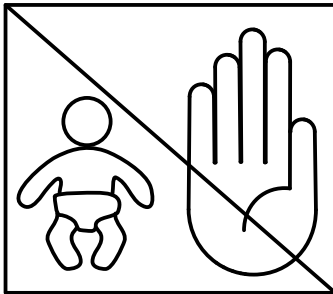
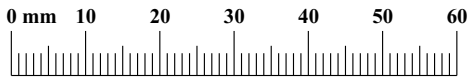

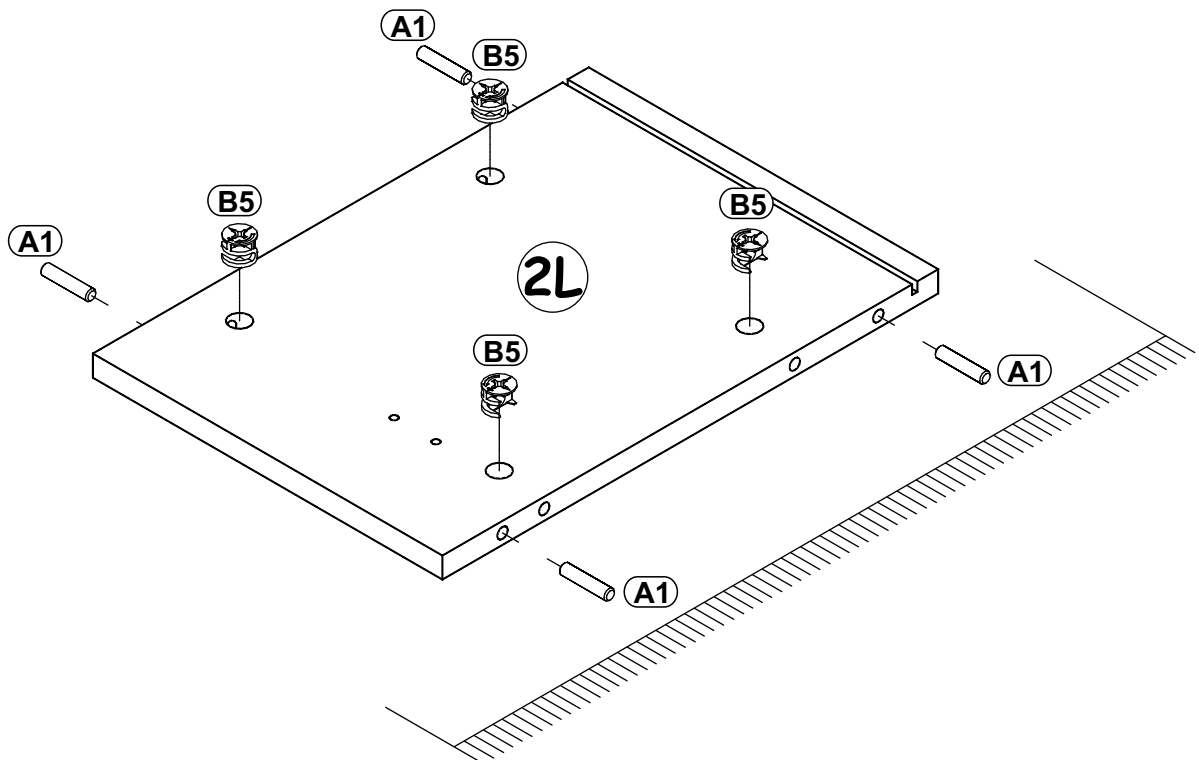
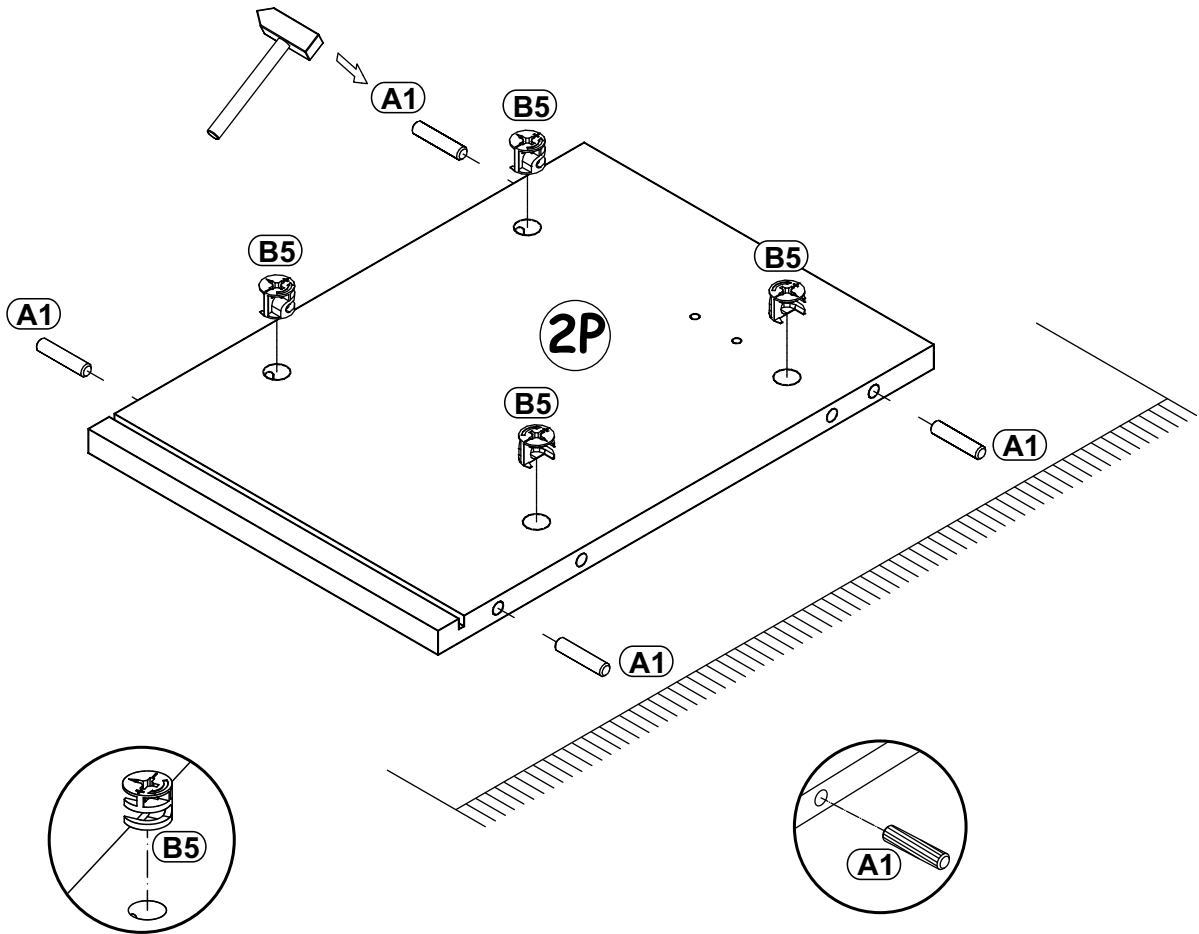
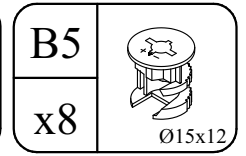
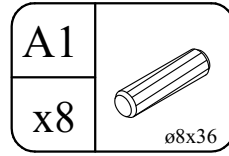

QUILL TYP 30

1



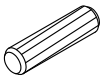

QUILL TYP 30

2

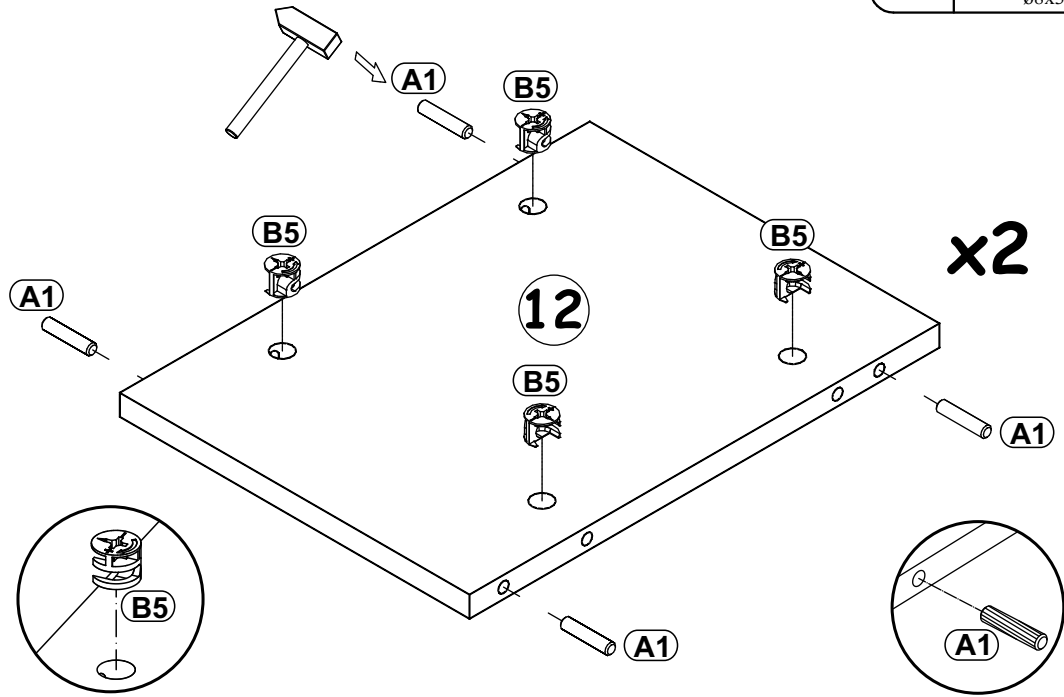
A1		B5	
x8	ø8x36	x8	Ø15x12

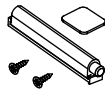

3

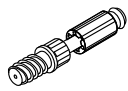
OD2		D10		B4	
x1		x2	USØ3,5x13	x8	

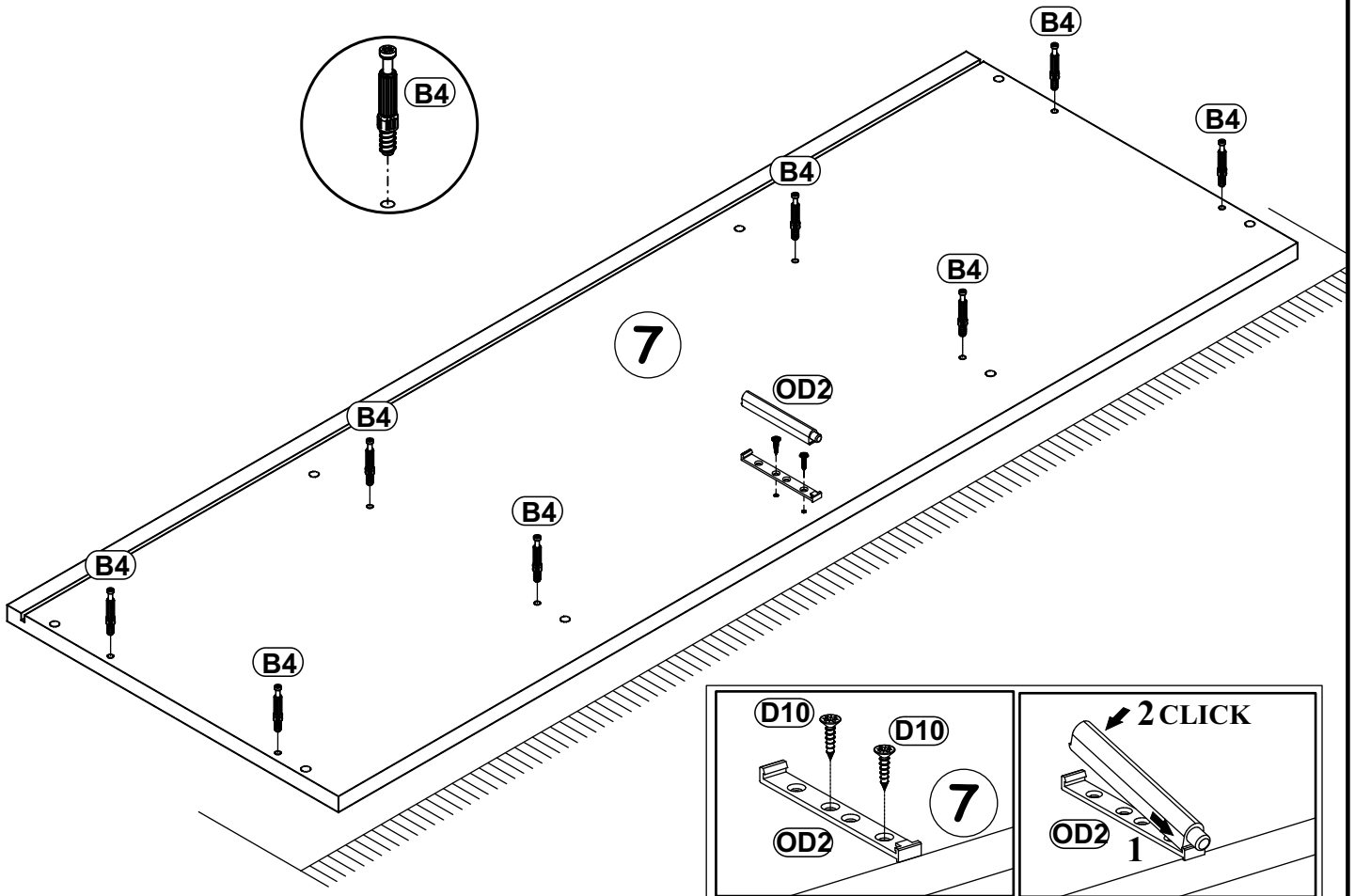

QUILL TYP 30

4

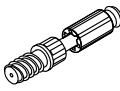
B4	
x8	

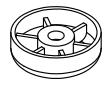
I11	
x6	Ø45, h=15

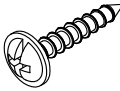
UP11	
x6	UPØ4x20

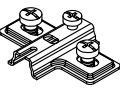
E2	
x3	H=0

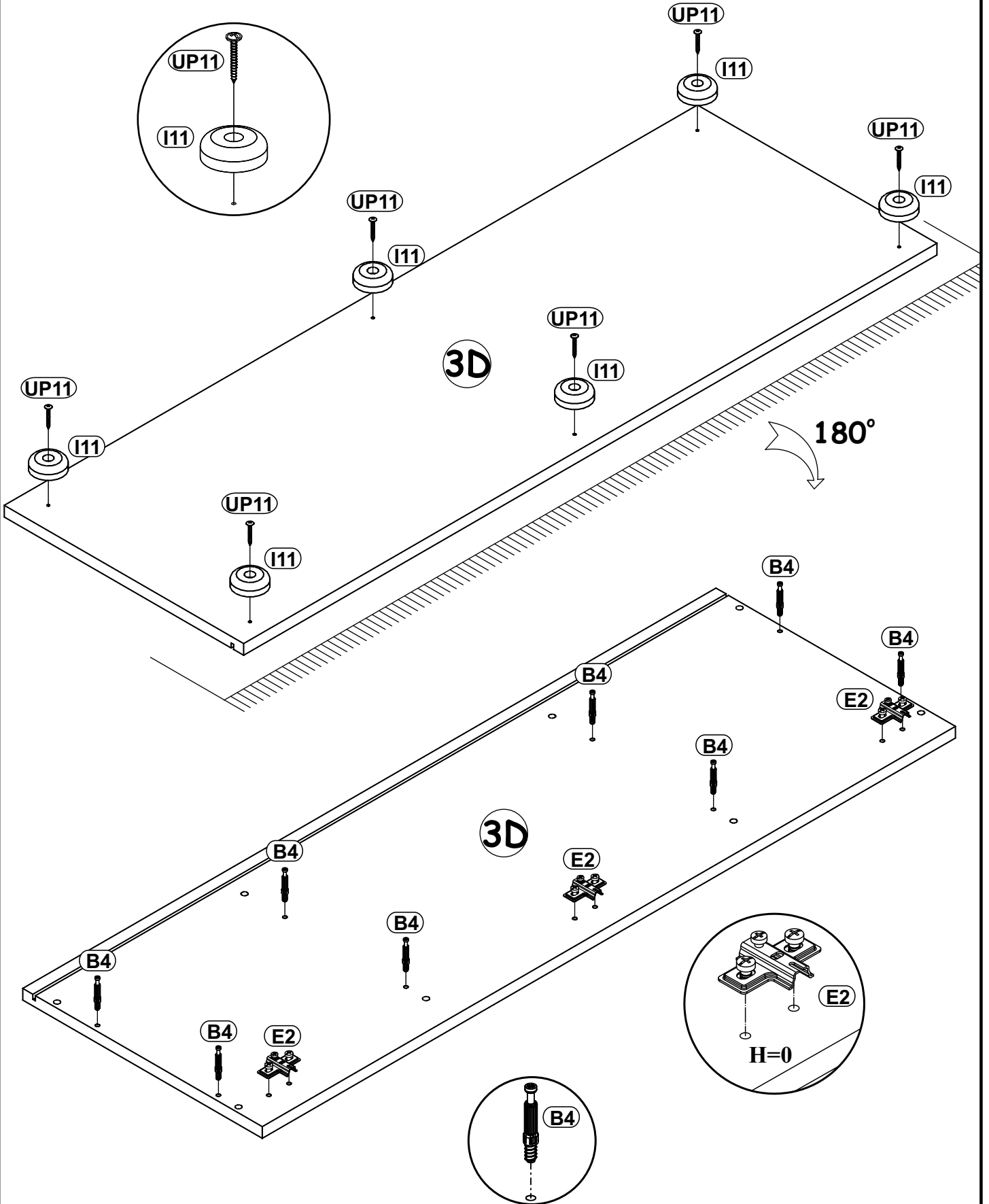

QUILL TYP 30

5

E21	Ø35	D10	 USØ3,5x13
x3	H=0	x6	

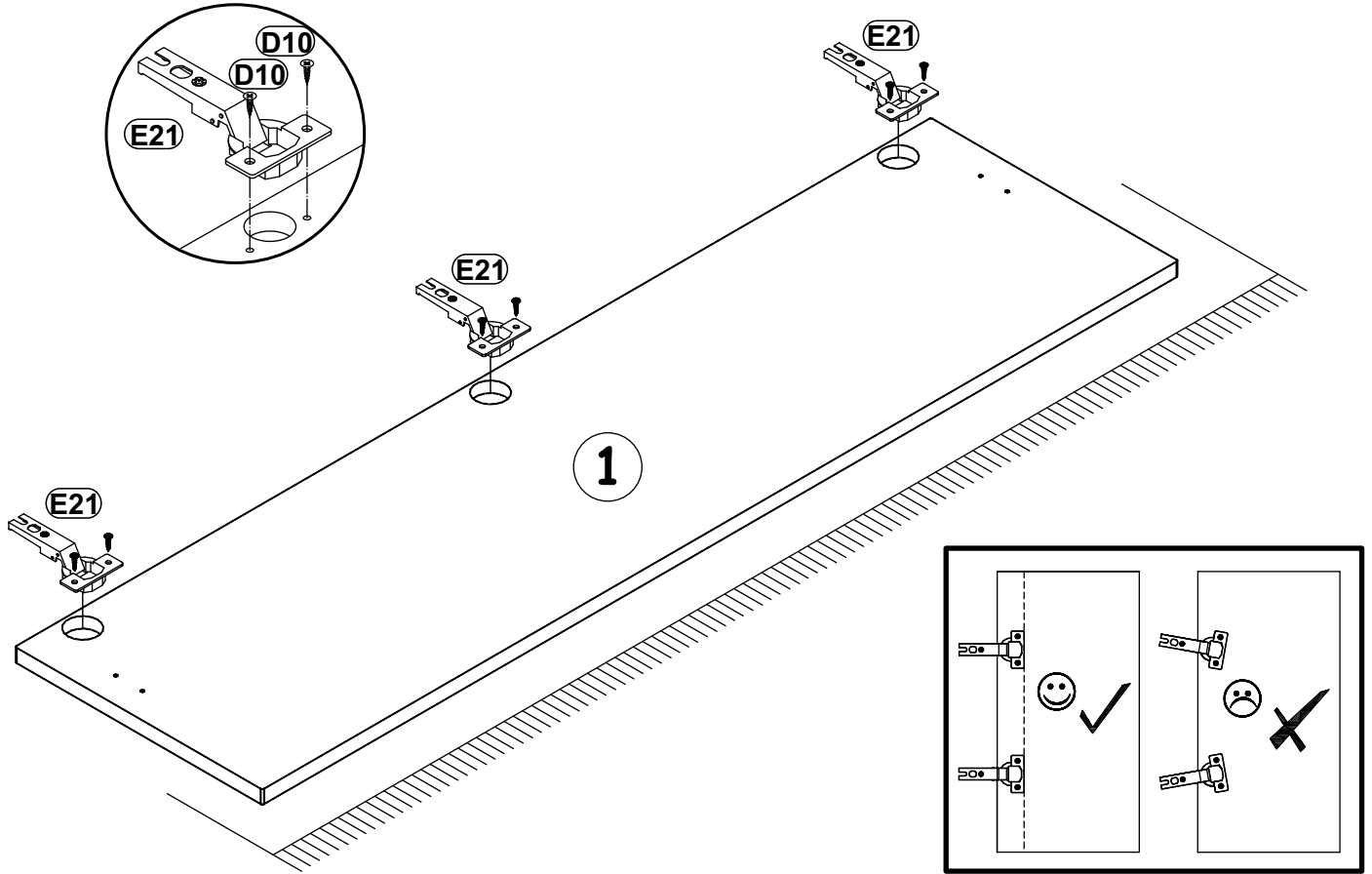

6

G5	
x8	

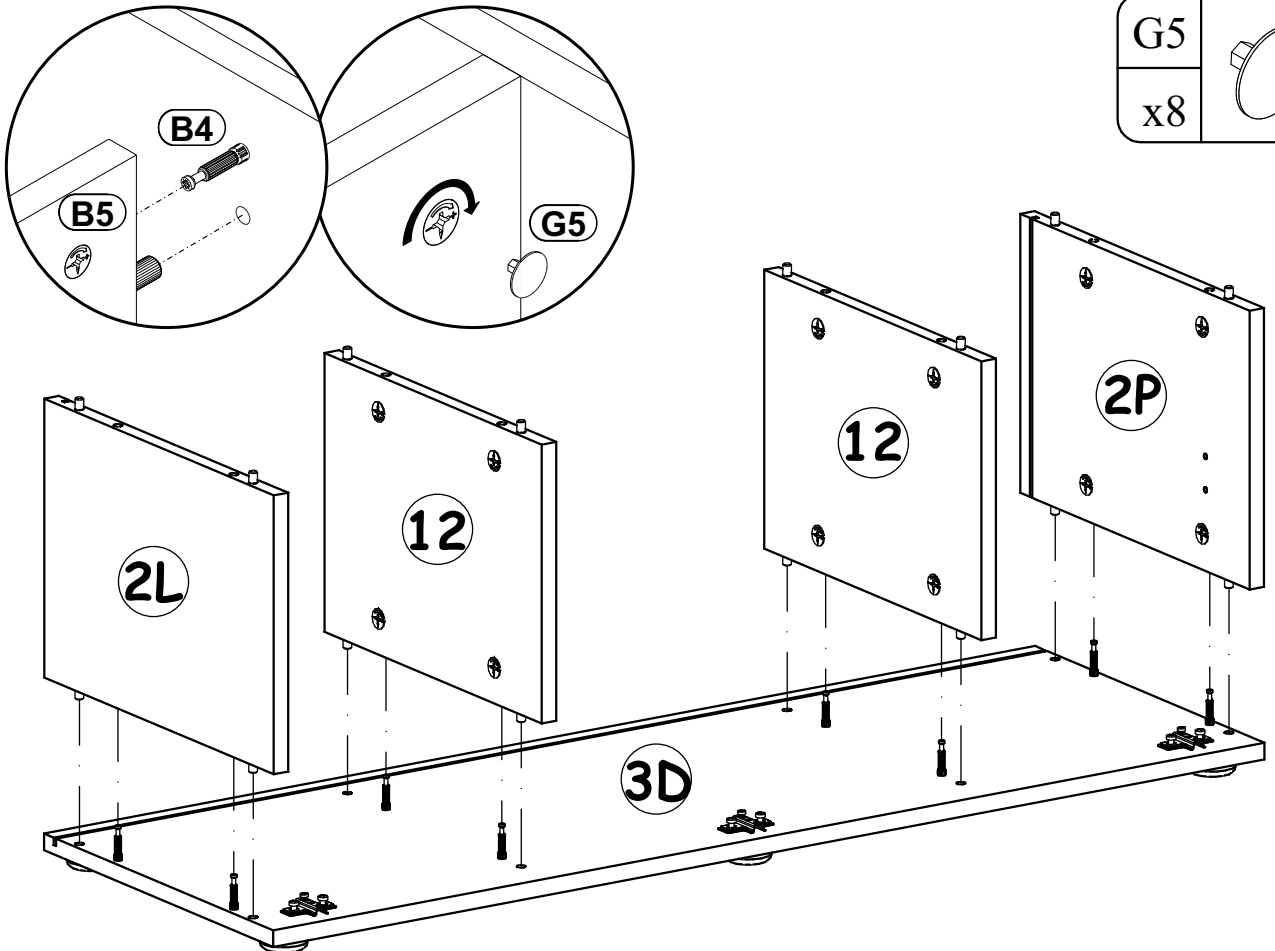

QUILL TYP 30

7

G5

x8

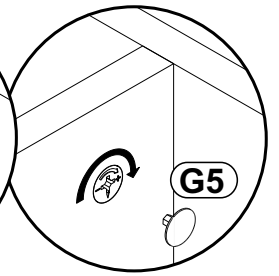
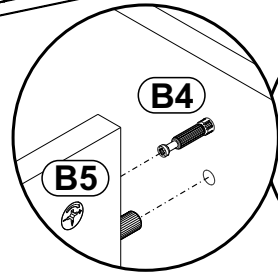
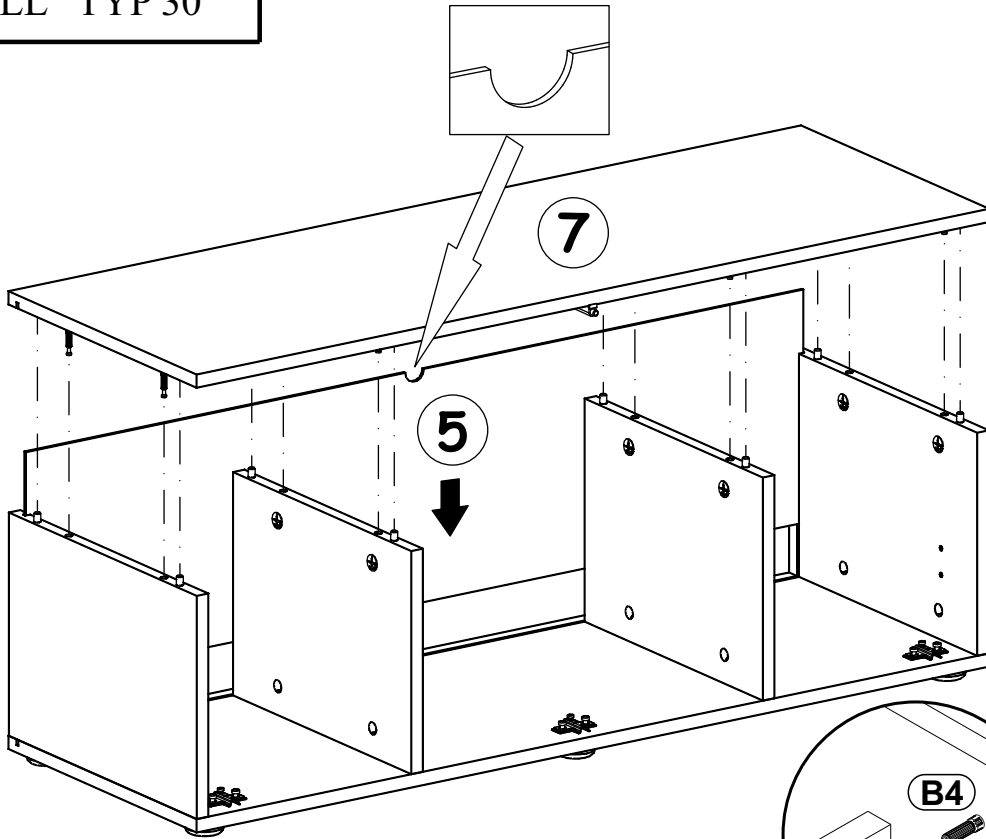

8

S1

x10

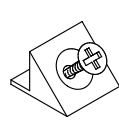

UP13

x2



UPØ3x16

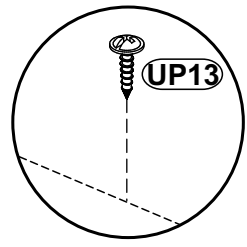
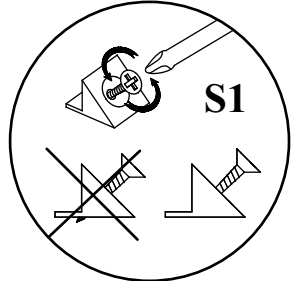

X=Y 90°

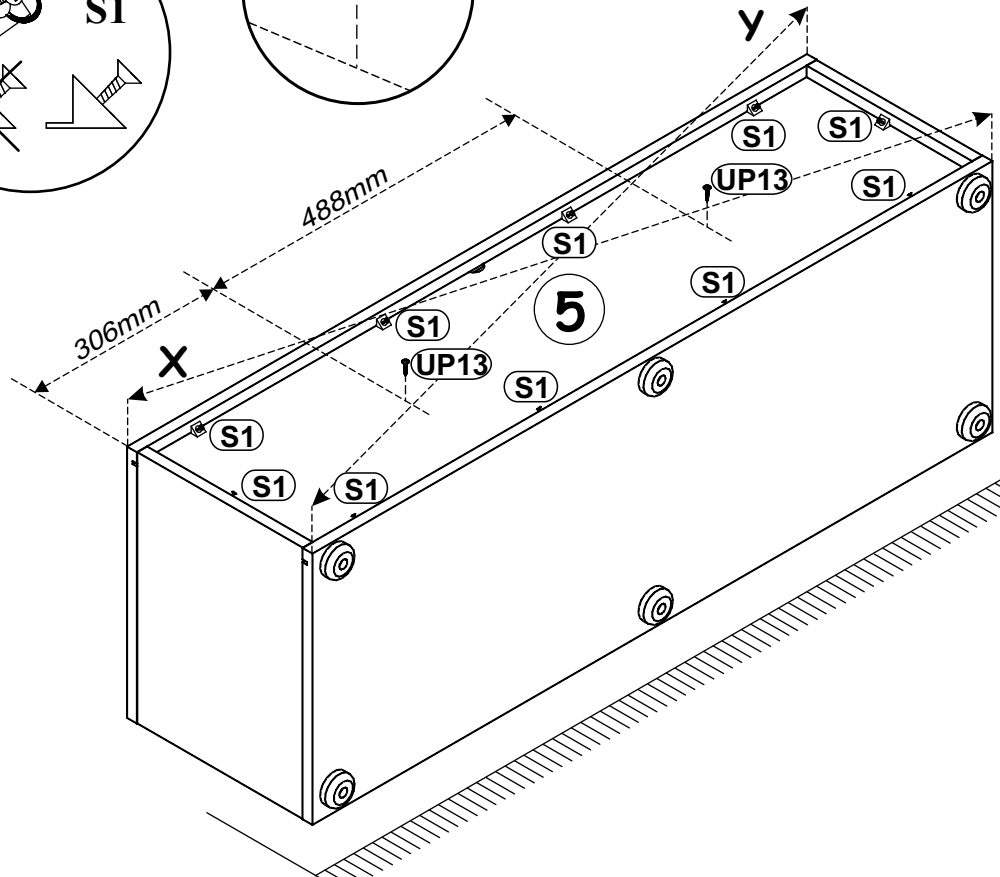
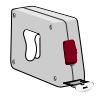

QUILL TYP 30

9

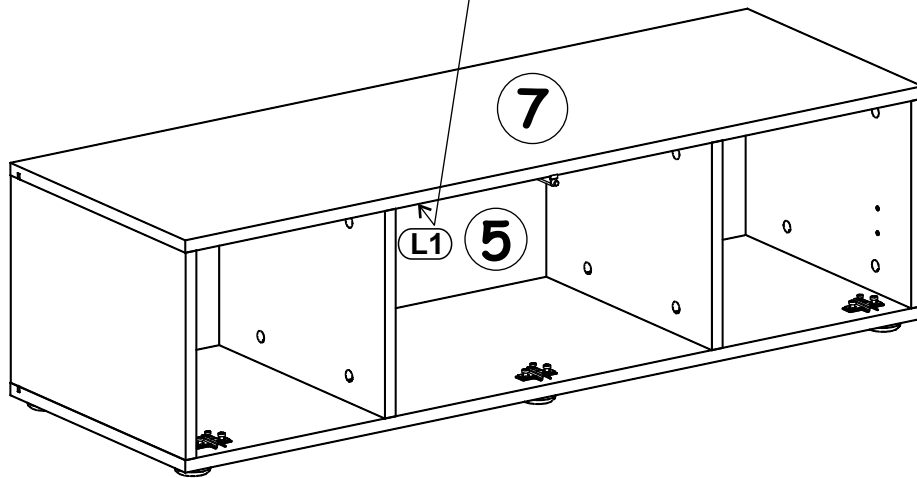
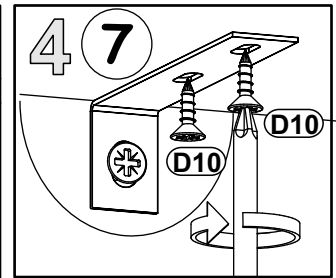
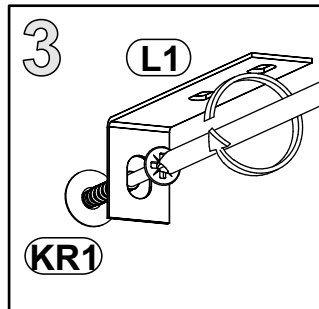
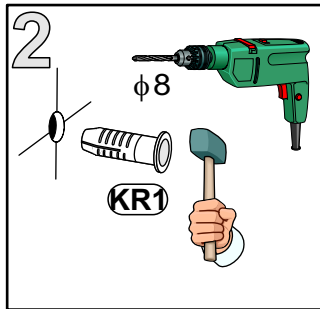
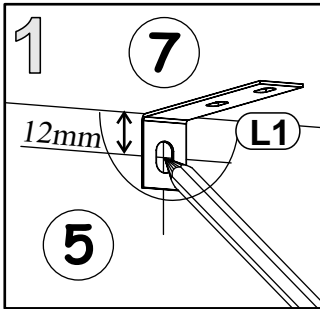
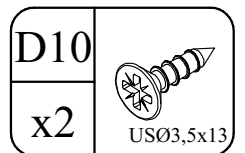
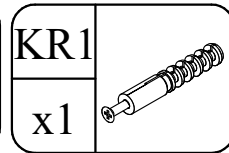
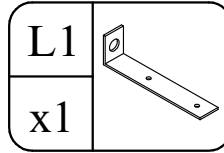
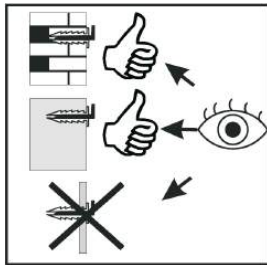

10

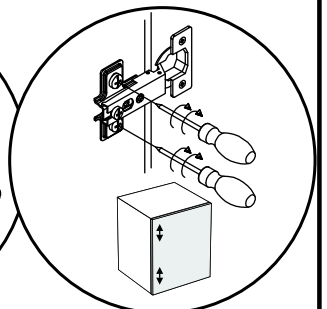
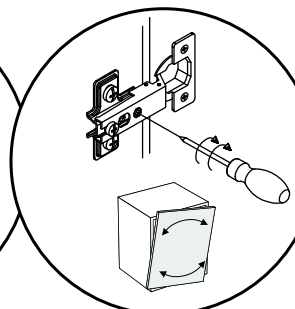
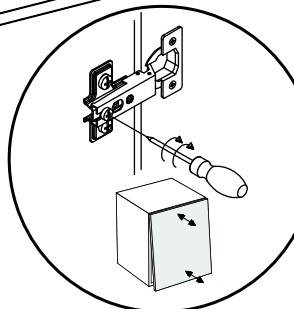
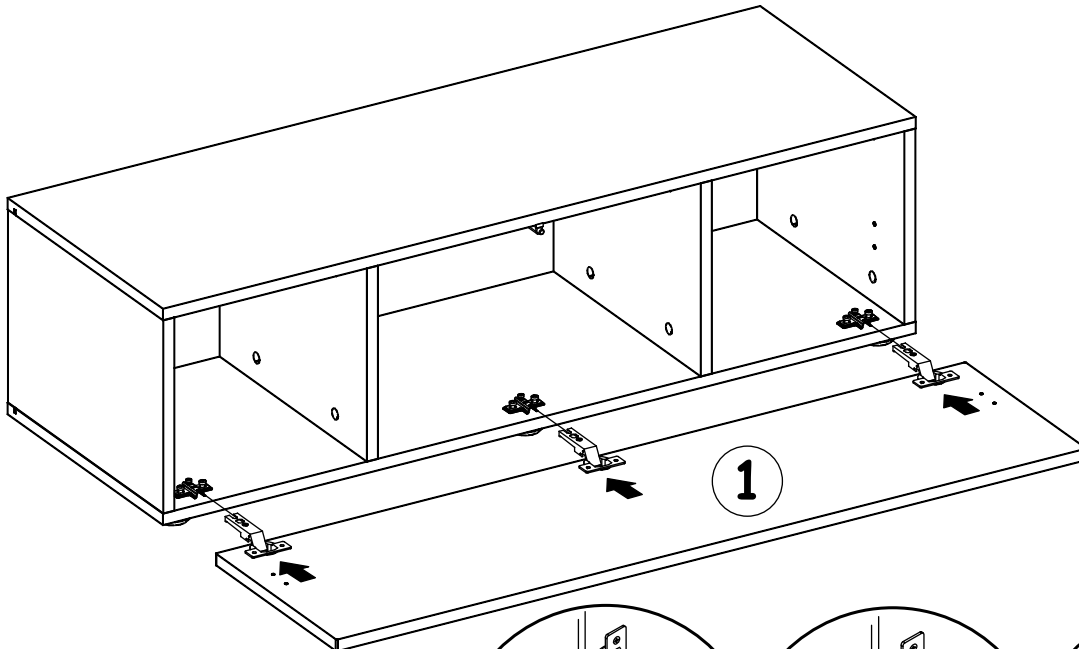

11

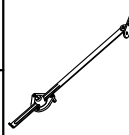
G21	
x2	

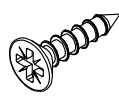
D7	
x6	USØ3x16

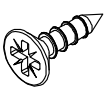
D10	
X4	USØ3,5x13

